



REVOLVING DOORS

# Revo.PRIME TSA 325 NT



# Contents

Revolving door systems	4
Overview	5
General information (types of drive units, number of door leaves, passage capacity)	6
<b>REVO.PRIME</b>	
Revo.PRIME	12
<b>TSA 325 NT</b>	
TSA 325 NT BO	16
TSA 325 NT RC2	19
TSA 325 NT GG	21
<b>ACTIVATION DEVICES AND SERVICE TOOLS</b>	
Activation	26
Protection	27
Operation	29
Service tools	30
<b>INSTALLATION DRAWINGS</b>	
Revo.PRIME / TSA 325 NT	32
<b>CABLE PLANS</b>	
Revo.PRIME	36
TSA 325 NT	37
<b>REFERENCE PROJECTS</b>	
Revo.PRIME/TSA 325 NT	38

# Revolving door systems

## FOCAL POINT OF THE ENTRANCE AREA

The most beautiful way to say welcome. GEZE revolving doors fulfil multiple purposes at entrances of public buildings. Safe, convenient and in an elegant design, they enable people to come in and go out without disruption. And anything that needs to stay outside remains outside, such as unpleasant weather or draughts. This increases the energy efficiency of the building. You can choose between a manual or automatic version, depending on how much visitor traffic your door needs to manage. We are happy to answer any questions you may have about revolving door systems.

As a highlight, the GEZE Revo.PRIME revolving door impresses thanks to the minimal canopy height of just 75 mm with a barely visible drive unit. Thanks to narrowest profile systems, it also impresses with maximum design in the entrance area – for more free space, more transparency, and an open airy feeling. It thus fulfils – like all other variants – the most stringent demands, and gets planners, operators and building users excited.

## ADVANTAGES AT A GLANCE

- Prestigious entrance with sophisticated looks thanks to the minimal canopy height and narrow profile systems for greater transparency
- High-quality materials, state-of-the-art control technology and advanced drive technology guarantee high ease of access with low energy consumption for an open and airy feeling
- Greater insulation effect against draughts, the weather and noise
- Suitable for large numbers of visitors
- Greater creative freedom thanks to individual planning and production for each project
- Fast installation due to a high degree of prefabrication ex works
- Simple and effective parameter setting and maintenance with the GEZEconnects tool
- Approved in accordance with EN 16005/DIN 18650 in all variants

## OUR REVOLVING DOOR SYSTEMS

- **Revo.PRIME**  
Sophisticated revolving door system for manual or automatic operation with the most stringent demands in terms of design and ease of access
- **TSA 325 NT BO**  
Revolving door system for use in escape and rescue routes with break-out leaves
- **TSA 325 NT RC2**  
Burglar-resistant revolving door system with automatic night-time closer
- **TSA 325 NT GG**  
All-glass revolving door system for maximum transparency

# Overview

	Revo.PRIME	TSA 325 NT BO	TSA 325 NT RC2	TSA 325 NT GG
Manual operation	●	–	–	●
With speed limiter (optional)	●	–	–	●
With positioning device (optional)	●	–	–	●
Fully automatic operation	●	●	●	●
Servo function	–	–	–	●
Suitability for escape and rescue routes	–	●	–	–
Break-out function (BO)	–	●	–	–
Inner diameter (min.)	1800 mm	1800 mm	2500 mm	1800 mm
Inner diameter (max.)	3800 mm	3600 mm	3400 mm	3000 mm
For 3-leaf door systems	●	●	●	●
For 4-leaf door systems	●	●	●	●
Clear passage height*	3500 mm	3000 mm	3000 mm	3000 mm
Canopy height (min.)	75 mm	200 mm	200 mm	17 mm
Side elements version	10 mm LSG, 22 mm panel infill, special glass on request		10 mm LSG, special glass on request	16 mm GG, special glass on request
<b>Surfaces</b>				
Powder-coated according to RAL	●	●	●	●
Anodised aluminium E6/EV1	●	●	●	●
Coated with grit 240 stainless steel	●	●	–	●
Coated with polished stainless steel	●	●	–	●
Special coating on request	●	●	–	●
<b>Roof construction</b>				
Tin roof	●	–	–	–
Waterproof roof with waterspout	●	●	●	–
Dust protection roof with wood covering	–	●	●	–
Optical sheet metal covering	–	●	–	–
Glass roof	–	–	–	●
Lighting	with roof variant			–
Floor covering	Entrance mat			
Hot-air curtain system	Electric air curtain, hot water air curtain possible, depends on the ceiling construction			on request
Night-time closer layout	inside, outside		inside	outside
Night-time closer type	manual/automatic		automatic	manual
Night-time closer design	10 mm LSG, 22 mm insulating glass, 22 mm panel infill, special glass on request		10 mm LSG, special glass on request	10 mm LSG
Locking mechanism	manual, rod, electromechanical			manual
Door handles horizontal or vertical	●	●	●	●
Floor ring	●	●	●	●
Underfloor drive	●	–	–	●
Push pad	●	●	●	●
Statements of approval	EN 16005	EN 16005/DIN 18650		

● = Yes | – = Not available | \* = Higher on request

# General information

## TYPES OF DRIVE UNITS, NUMBER OF DOOR LEAVES, PASSAGE CAPACITY, DIMENSIONS, PASSAGE WIDTHS, MINIMUM CANOPY HEIGHTS

### TYPES OF DRIVE UNITS

#### Manual revolving door

Manual revolving doors are used where there is limited access frequency, and can have a diameter of up to approx. 3000 mm. Larger diameters (up to max. 3800 mm) are possible, however ease of access is significantly reduced due to the increased exertion of force and the increased friction of the brush. Manually operated revolving doors are available in three- and four-leaf versions, each of which is available as an all-glass variant. The doors can be operated by slightly pushing them. Safety features are not necessary in accordance with DIN 18650. Two modes of operation are available: 'Locked' and 'Manual'.

#### Option: Speed limiter

The optional speed limiter counteracts a further increase in peripheral speed as soon as the top limiting speed has been reached.

#### Option: Positioning device

The optional positioning device with a motor gear unit in the ceiling or the floor returns the door to the initial position with a minimum of force after manual opening so that it is ready for the next visitor. The door is thus always in the end position and leaves a well-ordered optical impression.

#### Fully automatic revolving door

The fully automatic door with movement detectors is suited for high access frequency. Thus this revolving door offers maximum comfort and smooth and trouble-free passage. These door systems can be produced up to a maximum inner diameter of 3800 mm. The automatic revolving door is activated via inside and outside movement detectors. Upon activation, the door accelerates and rotates at an automatic speed. The speed is adjustable and the time delay can be freely adjusted for the modes of operation 'summer' (longer delay) and 'winter' (no delay). As a further option, a push pad can be installed on the door inside and outside. When this push pad is activated, the revolving speed is reduced to allow wheelchair users or people with restricted mobility to pass through the revolving door without any problems. This reduced speed can also be adjusted. At the end of the time delay the revolving door reduces speed in all modes of operation and stops in the end position. The door leaves seal tightly against the side walls, thus leaving all environmental influences such as draughts, exhaust gases from vehicles, cold and noise outside the building.

### NUMBER OF DOOR LEAVES

#### The decision for a three- or four-leaf revolving door

The three-leaf revolving door has a slightly reduced passage capacity. However, it offers greater ease of access, since there is significantly more space between the door leaves. This higher comfort mainly accommodates people with restricted mobility who cannot adapt themselves easily to the revolving speed of the revolving door. This type of door is first choice for shopping centres. The passage width on the door opening is smaller than that of a four-leaf revolving door with the same diameter.

The four-leaf revolving door is the classic version with the highest capacity, suited for two-way traffic and large streams of visitors. Due to the symmetric construction, the drum of the revolving door is closed by two leaves. This results in an improved protection against environmental influences and an improved vestibule effect.

This type of door has a larger opening width and is optically very attractive due to its symmetrical form.

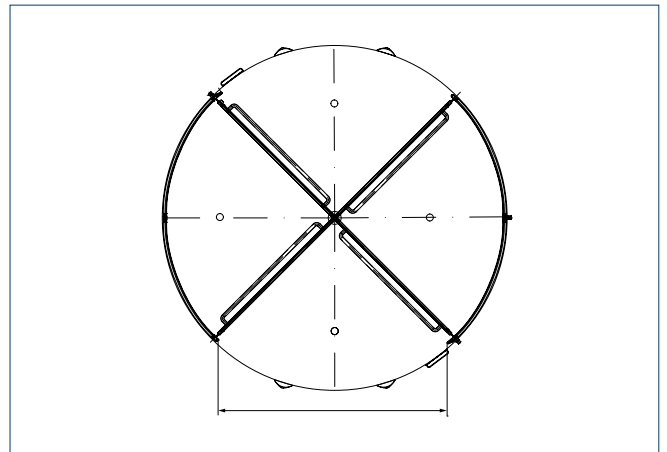
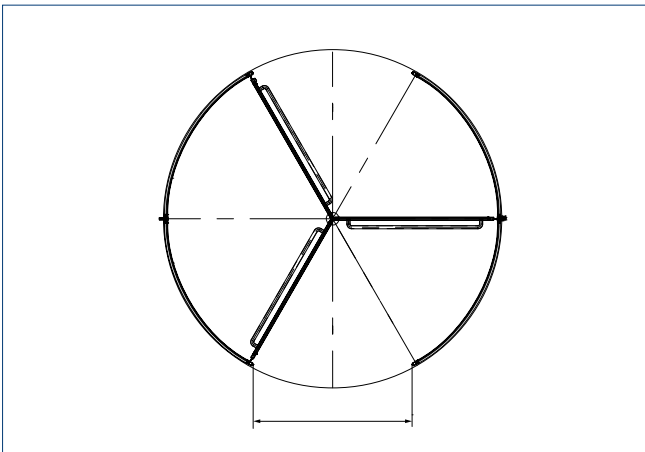

### PASSAGE CAPACITY

Inner diameter (as an example)	3-leaf		4-leaf	
	Capacity persons/hour	Persons/minute	Capacity persons/hour	Persons/minute
2000 mm	1203	20	1604	26
2400 mm	1002	16	1336	22
2800 mm	1718	28	2291	38
3200 mm	2256	37	3008	50
3600 mm	2005	33	2673	44
3800 mm	2280	38	2880	48

All stated values refer to the maximum capacity in one direction and a peripheral speed of 0.7 m/s.

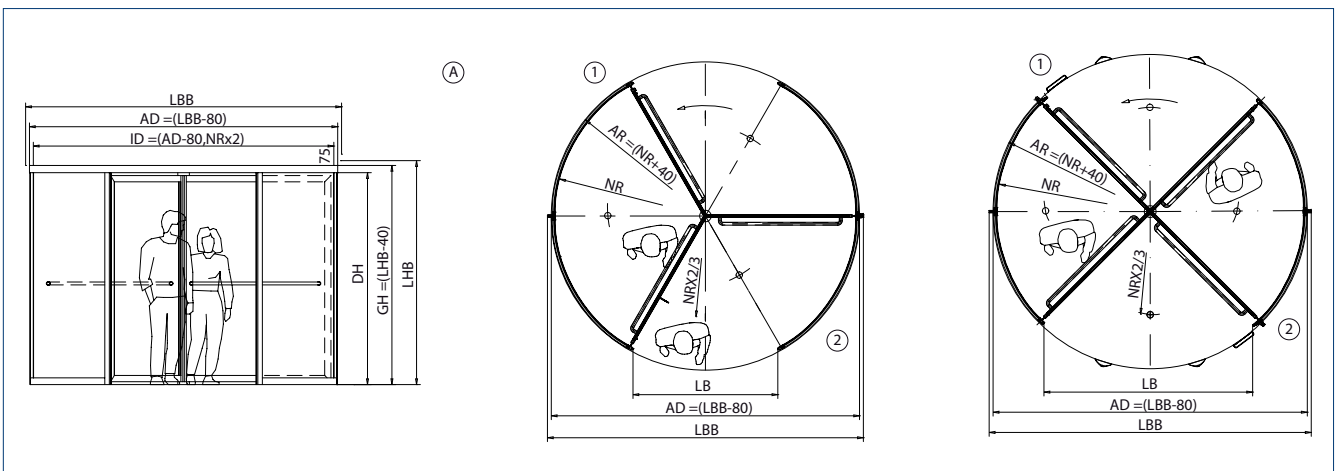

A = View variant, three-leaf | Floor plans variant three-leaf manual and four-leaf automatic variant | LBB = Clear passage width building (minimum distance to the side of the façade is 40 mm) | AD = External diameter | ID = Internal diameter | DH = Clear passage height | GH = Overall system height | LHB = Clear passage height building (minimum distance to the top is 40 mm) | NR = Nominal radius | LB = Passage width | 1 = Interior | 2 = Exterior

**PASSAGE WIDTHS FOR MANUAL REVOLVING DOORS**

	3-leaf	4-leaf
Inner diameter (as an example)	Glass in frame	Glass in frame
2000 mm	945 mm	1370 mm
2400 mm	1145 mm	1652 mm
2800 mm	1345 mm	1934 mm
3200 mm	1545 mm	2216 mm
3600 mm	1745 mm	2498 mm
3800 mm	1844 mm	2645 mm

**PASSAGE WIDTHS FOR AUTOMATIC REVOLVING DOORS**

	3-leaf	4-leaf
Inner diameter (as an example)	Glass in frame	Glass in frame
2000 mm	895 mm	1325 mm
2400 mm	1097 mm	1609 mm
2800 mm	1297 mm	1893 mm
3200 mm	1497 mm	2177 mm
3600 mm	1697 mm	2461 mm
3800 mm	1795 mm	2604 mm

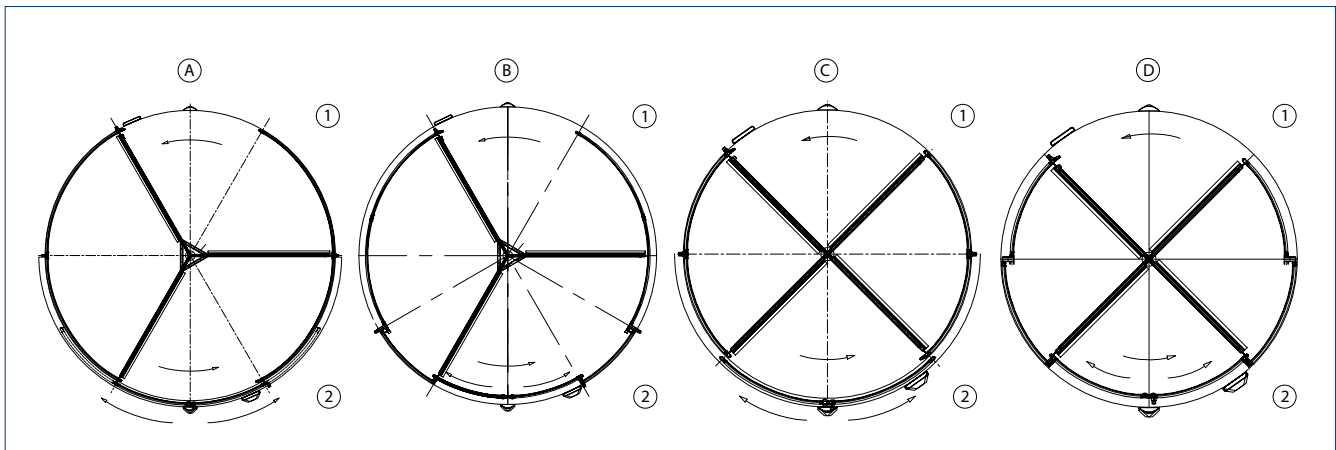

A = Three-leaf with outside-running night-time closer | B = Three-leaf with inside-running night-time closer | C = Four-leaf with outside-running night-time closer | D = Four-leaf with inside-running night-time closer | 1 = Inside | 2 = Outside





Flight Forum, Eindhoven, Netherlands (photo: Erwin Kamphuis/GEZE GmbH)



## REVOLVING DOORS

# Revo.PRIME

This door system plays the starring role when it comes to creative freedom and transparency in the entrance area of your building. A minimum canopy height of just 75 mm and a barely visible drive unit make this possible. And that's not all: with a narrow profile system of just 60 mm, this revolving door really steals the show. Advanced drive technology ensures maximum ease of access and safety when passing through the door. And because our energy is precious, this system runs with low consumption and thus scores highly in terms of sustainability.



# Revo.PRIME



Automatic revolving door system with low canopy height and narrow profile system for three- or four-leaf doors

## AREAS OF APPLICATION

- Three- and four-leaf door systems
- Interior and exterior doors with high access frequency
- Prestigious building entrances with major light incidence
- Façades with narrow post-rail constructions
- Glass façades with maximum design appeal
- Inner diameters of 1800 to 3800 mm possible
- Suitable profile systems are fine-framed profile system with insulating and mono glass

## PRODUCT FEATURES

- Very quiet-running, low-wear drive solution with a canopy height of just 75 mm
- Precise closing between door leaves and side walls
- High insulation effect against draughts, the weather and noise
- Adjustable automatic speed to suit the number of people passing through
- Door can be operated manually, e.g. for carrying out cleaning work
- Can be connected via CAN bus and integrated into building technology management systems
- Independent error recognition and recording
- Freely configurable inputs and outputs for different functions
- Integrated rechargeable battery for emergency opening in the event of safety-relevant faults such as a power failure

## TECHNICAL DATA

	Revo.PRIME
Manual operation	●
With speed limiter (optional)	●
With positioning device (optional)	●
Fully automatic operation	●
Inner diameter (min.)	1800 mm
Inner diameter (max.)	3800 mm
For 3-leaf door systems	●
For 4-leaf door systems	●
Clear passage height	3500 mm
Canopy height (min.)	75 mm
Side elements version	10 mm LSG, 22 mm panel infill, 34 mm smooth panel, special glass on request
Roof construction	Dust protection roof with wood covering, optical sheet metal covering, waterproof roof with waterspout
Lighting	with roof variant
Floor covering	Entrance mat, floor mat, according to customer preference
Hot-air curtain system	Electric air curtain, hot water air curtain possible depending on the ceiling construction
Night-time closer layout	Inside, outside
Night-time closer type	manual, automatic
Night-time closer design	10 mm LSG, 22 mm insulating glass, 22 mm panel infill, special glass on request
Locking mechanism	manual rod, electromechanical
Door handles horizontal or vertical	●
Floor ring	●
Underfloor drive	●
Push pad	●
Statements of approval	EN 16005

● = Yes





## REVOLVING DOORS

# TSA 325 NT

Revolving doors from the TSA 325 NT series are characterised by their high degree of variability. We are able to deliver individual, project-specific solutions with a choice of diameters ranging from 1800 to 3600 mm. All-glass revolving doors with drum walls, door leaves and glass ceilings create a particularly impressive effect. The speed of your automatic door can be adjusted to the number of people passing through at the same time as adhering to all safety technology parameters. Sensors and activation devices support safe passage through the door.



# TSA 325 NT BO



GEZE GmbH, Leonberg, Germany (photo: Martin Jakop/GEZE GmbH)

## Automatic revolving door system for escape and rescue routes with break-out function

### AREAS OF APPLICATION

- Three- and four-leaf door systems in escape and rescue routes
- Interior and exterior doors with maximum safety requirements
- Prestigious building entrances with major light incidence
- Façades with narrow post-rail constructions
- Glass façades with maximum design appeal
- Inner diameters of 1800 to 3600 mm possible
- Suitable profile systems are fine-framed profile system with insulating and mono glass



## PRODUCT FEATURES

- BO function allows the leaves and side elements to swing open in the direction of escape
- Electrical locking mechanisms for 'night' mode of operation integrated
- Very quiet-running, low-wear drive solution with at least 200 mm canopy height
- Precise closing between door leaves and side walls
- High insulation effect against draughts, the weather and noise
- Adjustable automatic speed to suit the number of people passing through
- Door can be operated manually, e.g. for carrying out cleaning work
- Can be connected via CAN bus and integrated into building technology management systems
- Independent error recognition and recording
- Freely configurable inputs and outputs for different functions
- Integrated rechargeable battery for emergency opening in the event of safety-relevant faults such as a power failure

## TECHNICAL DATA

### TSA 325 NT BO

Fully automatic operation	●
Suitability for escape and rescue routes	●
Break-out function (BO)	●
Inner diameter (min.)	1800 mm
Inner diameter (max.)	3600 mm
For 3-leaf door systems	●
For 4-leaf door systems	●
Clear passage height*	3000 mm
Canopy height (min.)	200 mm
Side elements version	10 mm LSG, 22 mm panel infill, special glass on request
Surfaces	Powder-coated according to RAL, anodised aluminium E6/EV1, covered with grit 240 stainless steel, covered with polished stainless steel, special coating on request
Roof construction	Dust protection roof with wood covering, optical sheet metal covering, waterproof roof with waterspout
Lighting	with roof variant
Floor covering	Entrance mat
Hot-air curtain system	Electric air curtain, hot water air curtain possible depending on the ceiling construction
Night-time closer layout	Outside: outside-running, outside: inside-running, inside: outside-running, inside: inside-running
Night-time closer type	manual, automatic
Night-time closer design	10 mm LSG, 22 mm insulating glass, 22 mm panel infill, special glass on request
Locking mechanism	manual, rod, electromechanical
Door handles horizontal or vertical	●
Floor ring	●
Push pad	●
Statements of approval	EN 16005/DIN 18650

● = Yes | \* = Higher on request

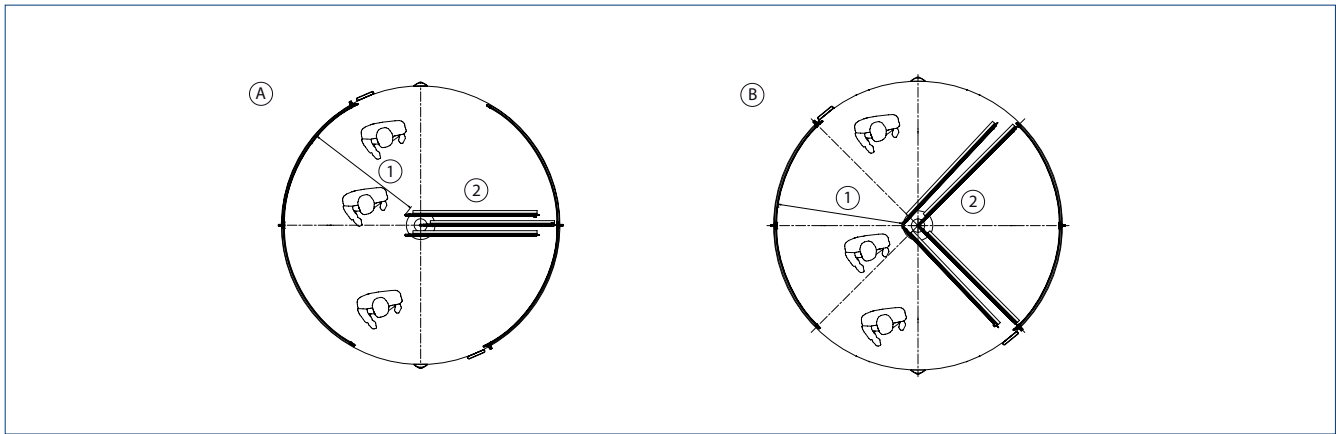

TSA 325 NT BO variants

A = Three-leaf | B = Four-leaf | 1 = Escape route width | 2 = Side-hung leaf opened

### WIDTH OF ESCAPE ROUTE

	3-leaf	4-leaf
Inner diameter	Width of escape route (FWB)	Width of escape route (FWB)
1800 mm	650 mm	660 mm
2000 mm	750 mm	760 mm
2200 mm	850 mm	860 mm
2400 mm	950 mm	960 mm
2600 mm	1050 mm*	1060 mm*
2800 mm	1150 mm*	1160 mm*
3000 mm	1250 mm*	1260 mm*
3200 mm	1350 mm*	1360 mm*
3400 mm	1450 mm*	1460 mm*
3600 mm	1550 mm*	1560 mm*

\* = Suitable for escape and rescue routes

Breaking out of a leaf will result in immediate disconnection of the drive unit. Afterwards it is possible to move the leaves manually (even when broken out).

Due to the manual breaking out function, the use of TSA 325 NT BO is limited to max. 220 N in areas with increased wind load. Depending on the diameter and the clear height, GEZE revolving doors can be used up to a wind speed of max. 6 Beaufort (Bft). This is equal to approx. 49 km/h. If the leaves are only used for ventilation and transport purposes, the break-out force can be increased, which will result in an increased break-out resistance in the case of wind pressure.

To prevent people from entering the building through the break-out leaves, two leaves must be locked at the minimum. This can be done as follows:

- two electromechanical locking mechanisms on the turnstile  
or
- night-time closers on sliding doors (automatic or manual)

→ **Note:** The use of revolving doors in escape and rescue routes must be according to local safety regulations and planning laws.

# TSA 325 NT RC2



BAU trade fair, GEZE booth, Munich, Germany (photo: Lazaros Filoglou/GEZE GmbH)

## Automatic revolving door system with burglar resistance in accordance with resistance class 2

### AREAS OF APPLICATION

- Three- and four-leaf door systems
- Interior and exterior doors with maximum safety requirements
- Prestigious building entrances with major light incidence
- Façades with narrow post-rail constructions
- Glass façades with maximum design appeal
- Inner diameters of 2500 to 3400 mm possible
- Suitable profile systems are fine-framed profile system with insulating and mono glass

### PRODUCT FEATURES

- Certified burglar resistance according to resistance class RC2
- The RC2 function is only available in 'Night' mode of operation, since the door does not have to fulfil any escape route stipulations
- Fitted with rod locking and reinforced profile components
- Very quiet-running, low-wear direct current drive solution with at least 200 mm canopy height
- Precise closing between door leaves and side walls
- High insulation effect against draughts, the weather and noise
- Adjustable automatic speed to suit the number of people passing through
- Can be connected via CAN bus and integrated into building technology management systems
- Independent error recognition and recording
- Freely configurable inputs and outputs for different functions
- Integrated rechargeable battery for emergency opening in the event of safety-relevant faults such as a power failure

### TECHNICAL DATA

#### TSA 325 NT RC2

Fully automatic operation	●
Inner diameter (min.)	2500 mm
Inner diameter (max.)	3400 mm
For 3-leaf door systems	●
For 4-leaf door systems	●
Clear passage height*	3000 mm
Canopy height (min.)	200 mm
Side elements version	10 mm LSG, special glass on request
Surfaces	Powder coated according to RAL, anodised aluminium E6/EV1, special coating on request
Roof construction	optical sheet covering, waterproof roof with waterspout
Lighting	with roof variant
Floor covering	Entrance mat
Hot-air curtain system	Electric air curtain, hot water air curtain possible depending on the ceiling construction
Night-time closer layout	inside
With speed limiter (optional)	●
With positioning device (optional)	●
Night-time closer type	automatic
Night-time closer design	10 mm LSG
Locking mechanism	manual, rod, electromechanical
Door handles horizontal or vertical	●
Floor ring	●
Push pad	●
Statements of approval	EN 16005/DIN 18650

● = Yes | \* = Higher on request

→ **Note:** The burglar-resistant function RC2 is only enabled in the 'Night' mode of operation.

# TSA 325 NT GG



FU Campus Dahlem, Berlin, Germany (photo: Stefan Dauth/GEZE GmbH)

## Automatic revolving door system for the realisation of all-glass solutions

### AREAS OF APPLICATION

- Three- and four-leaf all-glass door systems
- Interior and exterior doors with high access frequency
- Prestigious building entrances with major light incidence
- Façades with narrow post-rail constructions
- Glass façades with maximum design appeal
- Inner diameters of 1800 to 3000 mm possible

## PRODUCT FEATURES

- Very quiet-running, low-wear drive solution with at least 17 mm canopy height
- Drive and control technology are fully concealed in the floor
- Glass roof with reduced profiles for more transparency
- Reduced aluminium profiles with rounded edges create a modern look
- Drum walls in curved laminated safety glass (LSG)
- Door leaves made of fine-framed toughened safety glass
- Two half shells made of heat strengthened soda lime silicate glass form the roof which is held by stainless steel single point fixing holders
- Precise closing between door leaves and side walls
- High insulation effect against draughts, the weather and noise
- Adjustable automatic speed to suit the number of people passing through
- Door can be operated manually, e.g. for carrying out cleaning work
- Can be connected via CAN bus and integrated into building technology management systems
- Independent error recognition and recording
- Freely configurable inputs and outputs for different functions
- Integrated rechargeable battery for emergency opening in the event of safety-relevant faults such as a power failure

## TECHNICAL DATA

### TSA 325 NT GG

Manual operation	●
With speed limiter (optional)	●
With positioning device (optional)	●
Fully automatic operation	●
Servo function	●
Inner diameter (min.)	1800 mm
Inner diameter (max.)	3000 mm
For 3-leaf door systems	●
For 4-leaf door systems	●
Clear passage height*	3000 mm
Canopy height (min.)	17 mm
Side elements version	16 mm GG, special glass on request
Surfaces	Powder-coated according to RAL, anodised aluminium E6/EV1, covered with grit 240 stainless steel, covered with polished stainless steel, special coating on request
Roof construction	Glass roof
Lighting	not possible with glass roof
Floor covering	Entrance mat, floor mat, according to customer preference
Hot-air curtain system	on request
Night-time closer layout	outside
Night-time closer type	manual
Night-time closer design	10 mm LSG
Locking mechanism	manual
Door handles horizontal or vertical	●
Floor ring	●
Underfloor drive	●
Push pad	●
Statements of approval	EN 16005/DIN 18650

● = Yes | – = Not available | \* = Higher on request







## REVOLVING DOORS

# Activation devices and service tools

Sensors are the masterminds behind revolving doors, with a full focus on comfort and safety. Activation devices create accessibility and protect against accidents. Choose radar movement detectors or sensor switches for activation, sensor strips or active infrared detectors for protection, or programme switches to set the mode of operation of your automatic door. Our service tools make parameter setting simple.



# Activation

## RADAR MOVEMENT DETECTOR

Radar movement detectors register all objects that move within the radar field. All movements within the radiation range are recorded as a switching pulse which is forwarded as a door opening signal. The pre-programmed convenience setting of the GEZE radar movement detectors ensures fast commissioning. Automatic configuration is possible via the push buttons or a remote control. Reliable detection is achieved with a clearly defined radar field. Energy can be saved through the people movement direction detection. Unwanted door opening is avoided since cross-traffic can be faded out.



Radar movement detector GC 302

## SENSOR SWITCH

Just a light touch of the push button is sufficient to open your automatic revolving door. Thanks to illuminated LEDs, these push buttons are also easy to see in poor lighting conditions. A visual signal indicates activation through the sensor switch. Capacitive contact sensors, another name for these push buttons, fulfil the highest requirements for accessibility and hygiene. Don't have a free hand? Then our highly robust LED sensor foot switch is your first choice.



LED sensor switch glass



LED sensor switch 20 mm



LED sensor foot switch

# Protection

## SAFETY DEVICES AND SENSORS

### Movement detectors inside and outside

The movement detectors are fixed inside and outside on the ceiling canopy, and work on the basis of radar. They are used as activation devices for automatic revolving doors. The detection area of the sensor can be set.

### Leading mullion safety sensor

The leading mullion safety sensor is a presence detector that works on the basis of active infrared. It monitors the area in front of the mullion by means of an active infrared detector which is only activated as one of the leaves of the revolving door approaches the mullion. The detection area of the sensor can be set. Alternatively, a simpler sensor can be installed in the ceiling canopy. This simple sensor does not comply with DIN 18650 and is therefore not approved for use in Germany.

### Emergency-stop switch inside and outside

The emergency stop switch inside and outside is mounted to the static side element and triggers maximum braking in an emergency, which brings the revolving door to an immediately standstill. After it has been braked, the door can be rotated or operated in both directions.

### Keypad programme switch

The different modes of operation of an automatic revolving door can be set using the keypad programme switch.

### Key switch

The operation of the keypad programme switch by unauthorised persons can be prevented by installing a key switch.

### Warning notice inside and outside

Warning signs must be attached to all revolving doors to make parents aware of their duty to take care of their children.

### Push pad

The push pad is attached on the inside and outside of the static side element or nearby on the wall or façade. When the push pad is activated, the revolving speed of the revolving door is reduced to allow people with restricted mobility to pass. The speed and duration of activation can be set.

### Mullion safety

Mullion safety is a rubber safety strip which is fitted to the main closing edge on the fixed side element of the revolving door. This safety edge triggers emergency braking of the door when contacted. When emergency braking is triggered, the revolving door is slowed down until standstill, remains stopped for an adjustable period and then continues its movement in the set mode of operation and speed.

### Heel protection strip

The heel protection strip is a rubber safety strip that is attached horizontally to the bottom of a revolving door leaf. It prevents an obstacle or a person being caught by the revolving door leaves. As soon as the safety strip makes contact with an obstacle or a person, emergency braking is triggered and the revolving door stops immediately. When emergency braking is triggered, the revolving door is slowed down until standstill, remains stopped for an adjustable period and subsequently continues its movement in the set mode of operation and speed.

**Vertical safety contact strip**

The safety contact strip is a rubber safety strip which is attached vertically to the outer edge of the side-hung leaf and prevents people being drawn in. As soon as a person or a part of the body gets in contact with the safety strip, emergency braking is triggered and the revolving door is stopped immediately. When emergency braking is triggered, the revolving door is slowed down until standstill, remains stopped for an adjustable period and then continues its movement in the set mode of operation and speed.

**Mobile safeguarding device**

'Mobile safeguarding devices' are optical sensors which are fixed to the top edge of the side-hung leaves. They work on an infrared basis and optically monitor the area in front of the rotating leaves of a revolving door. As soon as the sensor recognises an obstacle or a person, the revolving door is slowed down. If the obstacle remains within the detection area of the sensor, the revolving speed is reduced to such an extent that the rotating leaf of the door comes to a standstill in front of the obstacle. The sensitivity and detection area of the sensors can be set.

**OPERATING ELEMENTS**

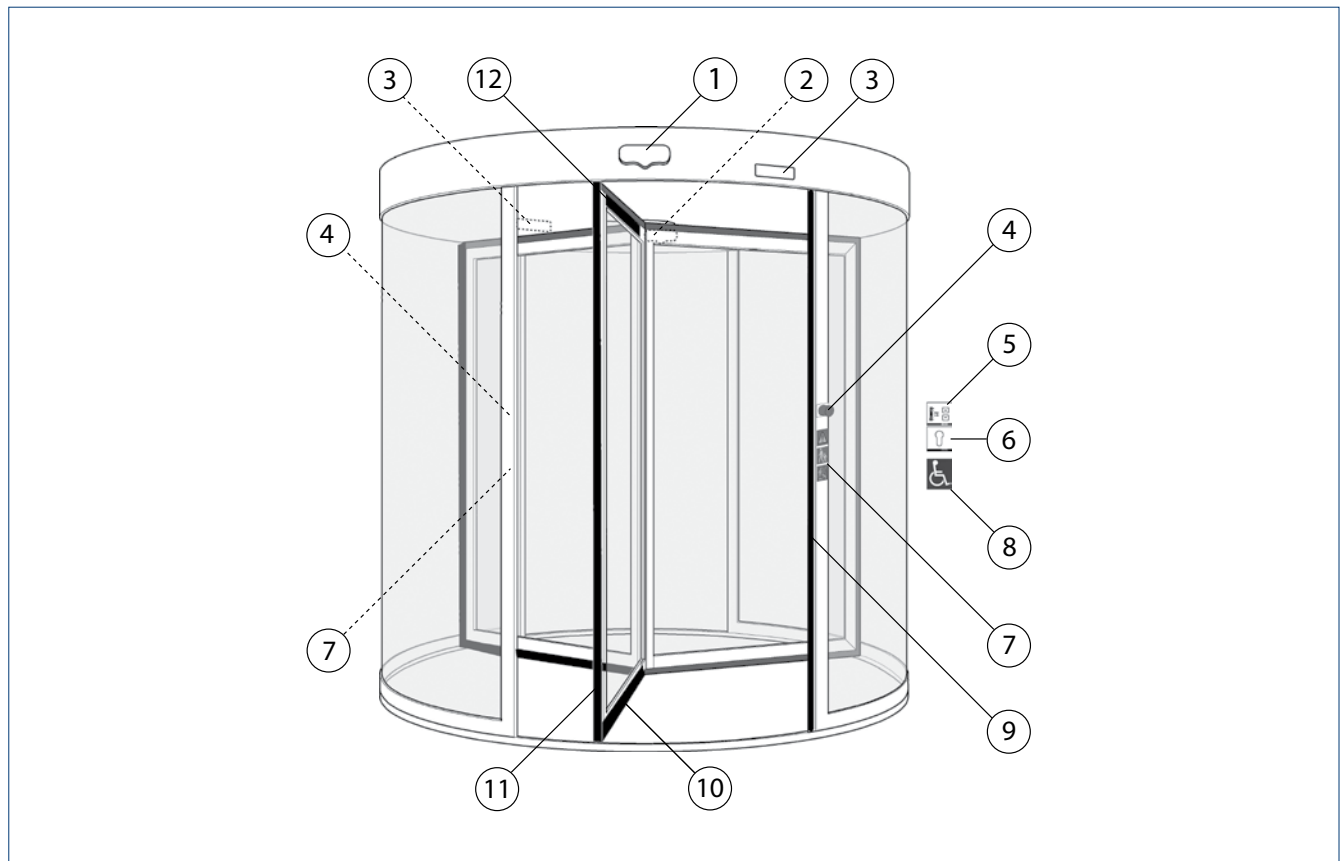

Keypad programme switch with key switch (TPS-SCT)

1 = Movement detector inside | 2 = Movement detector outside | 3 = Leading mullion safety sensor | 4 = Emergency-stop switch inside and outside | 5 = Keypad programme switch | 6 = Key switch | 7 = Warning sign inside and outside | 8 = Push pad (optional) | 9 = Mullion safety | 10 = Heel protection strip | 11 = Vertical safety contact strip | 12 = Mobile safeguarding device (optional)

**PROTECTION SENSOR STRIP, ACTIVE INFRARED DETECTOR, LASER SCANNER**



GC 338 sensor strip



GC 339 active infrared detector



FLATSCAN REV LZ

# Operation

## PROGRAMME SWITCH TO SELECT THE MODE OF OPERATION OF REVOLVING DOORS

The following modes of operation can be set:

### OFF

In the 'OFF' operating status, the motor gear unit is switched off and the door can be rotated freely by hand. This operating status is especially suitable for maintenance and cleaning of the door. All activation devices are switched off.

### Night mode

In the 'night mode' operating status, a wide range of different locking options can be selected for the revolving door.

- No locking
- Manual locking of the door leaves using a bar lock
- Locking using the electromechanical disc brake
- Electromechanical locking of the door leaves
- Locking with manual night-time closer
- Locking with automatic night-time closer

### Exit only

In the 'exit only' operating status, the door is activated by the internal movement detector only. It revolves a preset number of sectors at automatic speed and then stops in the end position.

### Automatic

All the connected pulse generators are active in the 'Automatic' operating status. After activation, the door accelerates to a preset automatic speed, rotates the preset number of sectors and then changes over to a reduced speed. The slow revolving speed and time delay can be set. Pressing both arrow keys at the same time changes the system to "winter mode". In this case, there is no time delay and the revolving door moves immediately to the end position. As an option, a push pad can be connected. When this push button is activated, the revolving speed is reduced so that people with restricted mobility can pass through the door without any problems. The revolving speed and time delay can also be set.

### Manual

The revolving door can be rotated freely in manual operation. If no further functions are set, the 'Manual' operating status is identical to the 'OFF' operating status. The following option can be set here: A positioning device automatically brings the door to the end position at slow speed following manual opening. Safety functions can be deactivated.

## PROTECTION OF THE PROGRAMME SWITCHES

Keypad programme switches can be combined with a key switch. This ensures that only the key-holder can make changes to the mode of operation. Key switches that are protected against vandalism can be used when the door has to be opened from the outside by authorised persons only.



Keypad programme switch (TPS)



Keypad programme switch with key switch (TPS-SCT)



Burglary-resistant key switch (TPS-SCT)

# Service tools

## SERVICE TOOLS

### GEZEconnects

Bluetooth is an internationally standardised short-distance radio signal with a range of up to ten metres. The GEZEconnects software makes wireless connection via Bluetooth possible between a computer and the automatic door systems from GEZE. All door system settings can be carried out via an intuitive graphic interface, stored, sent by e-mail and transferred to a word processing programme as a protocol. Diagnosis functions show the most important function parameters of the door system in real time, so that faults are recognised at a glance and can be eliminated. All the pre-settings can be taken over very easily for further door systems. The convenient documentation of commissioning, maintenance and diagnosis protocols as well as all statistical data can be downloaded at any time. Password protection to block operating parameters and servicing data guarantees security against unauthorised modifications.

### ST 220 service terminal

Mobile, handy and straightforward – that is parameter setting for the automatic GEZE door systems using the ST 220 service terminal. Communication and data exchange between the service terminal and the door drive is via an integrated RS485 interface. The large illuminated display is easy to operate thanks to the plain text display. The service terminal is equipped with a readout function for servicing and diagnosis work. Power is supplied via the door system. Password protection to block operating parameters and servicing data guarantees security against unauthorised modifications.



GEZEconnects



ST 220 service terminal



VGH Versicherungen company administrative building, Hanover, Germany (Photo: Lothar Wels/GEZE GmbH)

# Installation drawings Revo.PRIME/TSA 325 NT

## TYPES OF FLOOR RINGS

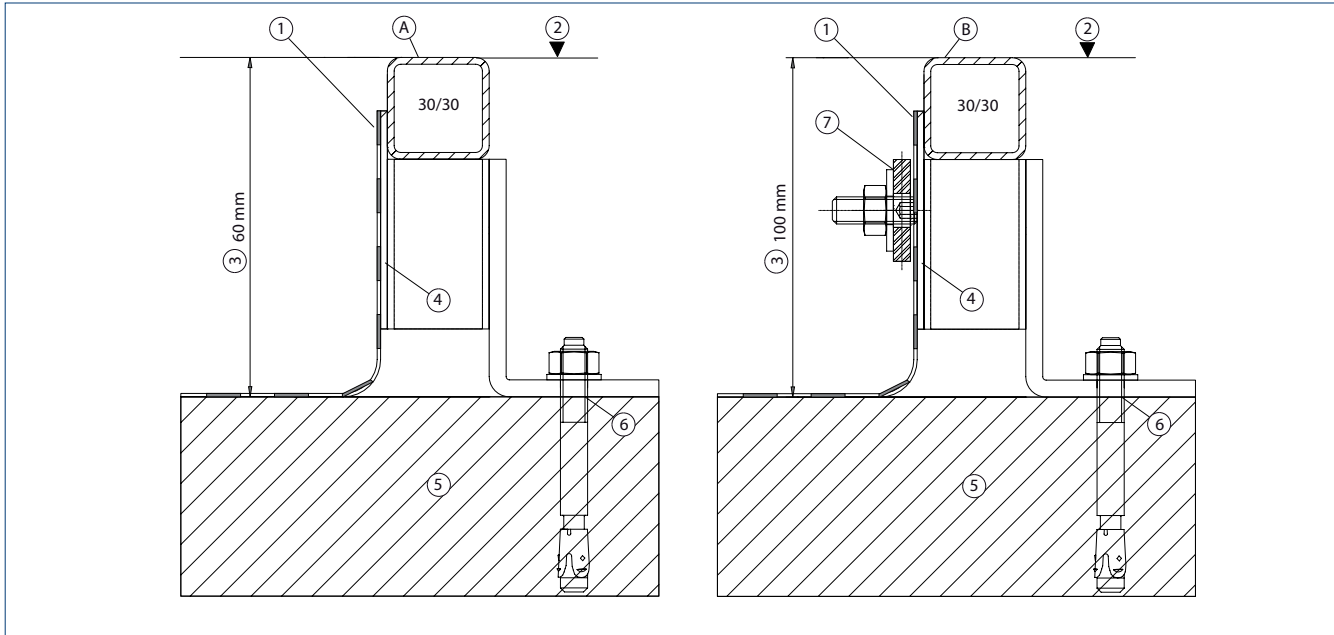

A = Stainless steel floor ring with retaining plate | B = Floor ring with loose and fixed flange | 1 = Seal on site | 2 = Finished floor level | 3 = Floor structure (min.) | 4 = Retaining plate | 5 = Unfinished floor | 6 = Fixing to unfinished floor | 7 = Loose and fixed flange



**SIDE ELEMENT STOP WITH NIGHT-TIME CLOSER REVO.PRIME / TSA 325 NT**

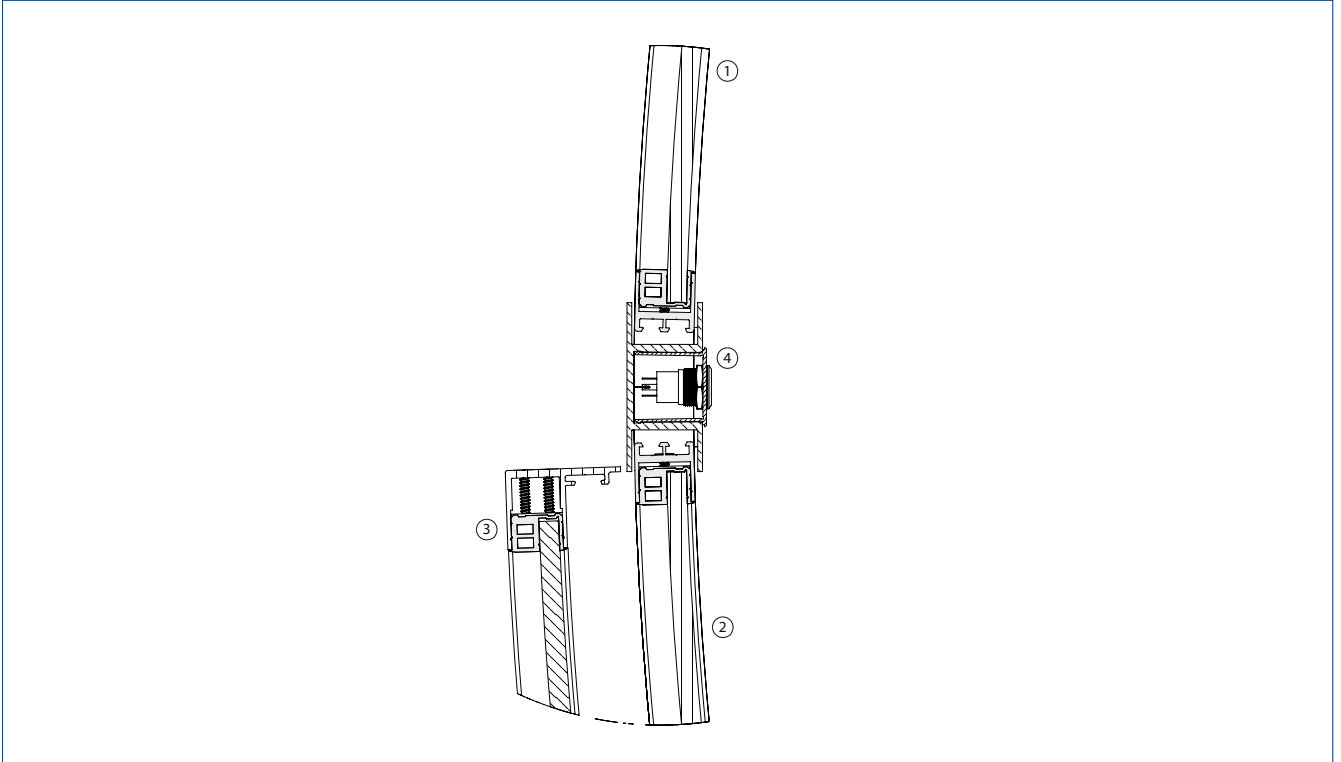

1 = Drum wall inside | 2 = Drum wall outside | 3 = Night-time closer on the outside | 4 = Side element stop | Release push button (optional)

**NIGHT-TIME CLOSER REVO.PRIME**

**DETAIL INSIDE-RUNNING NIGHT-TIME CLOSER SIDE ELEMENT STOP**

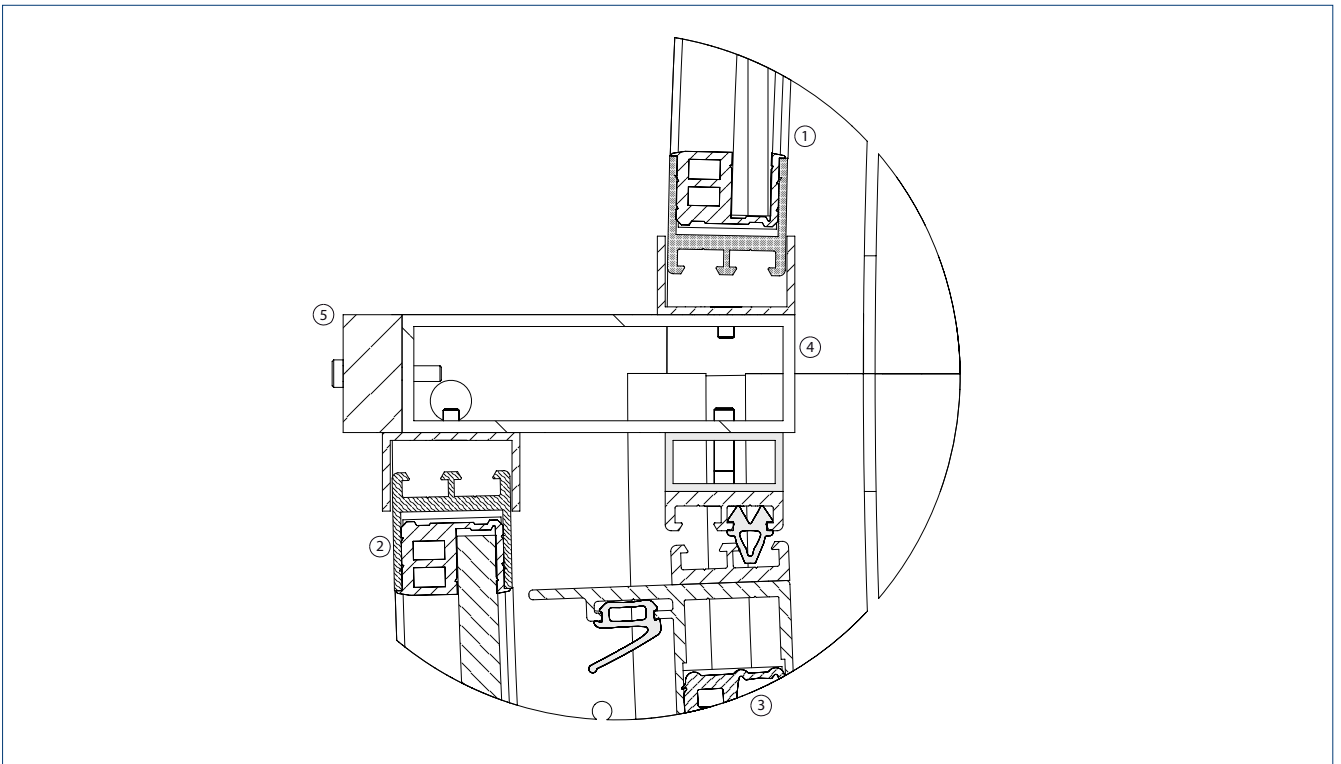

1 = Drum wall inside | 2 = Drum wall outside | 3 = Inside-running night-time closer | 4 = Side element stop | 5 = Façade connection

## REVO.PRIME CEILING VARIANTS

### STANDARD CEILING VARIANT

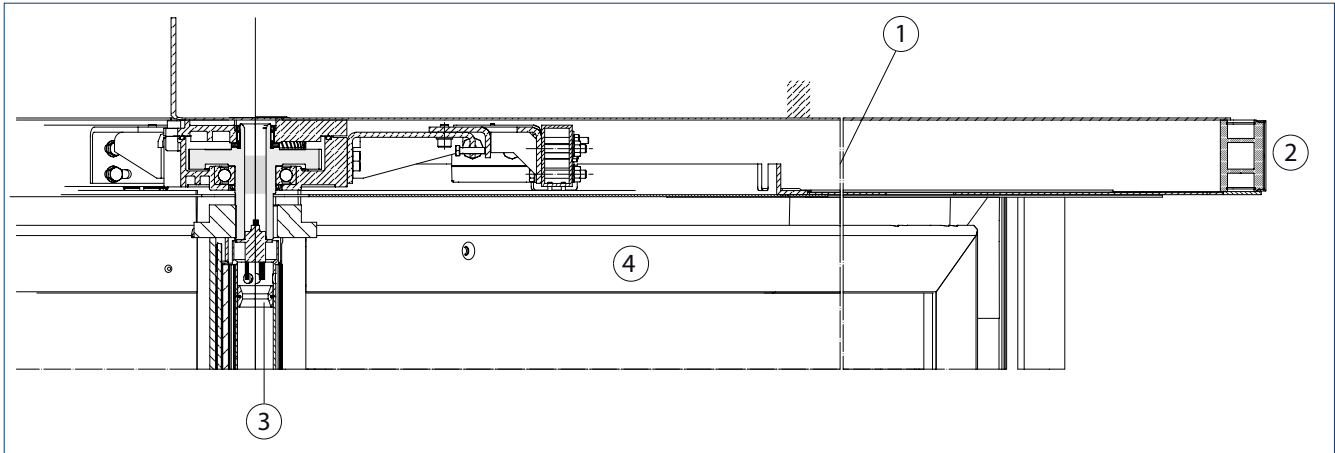

1 = Ceiling construction | 2 = Canopy profile | 3 = Swivelling axis | 4 = Side-hung leaf

### CEILING VARIANT WITH NIGHT-TIME CLOSER (NV)

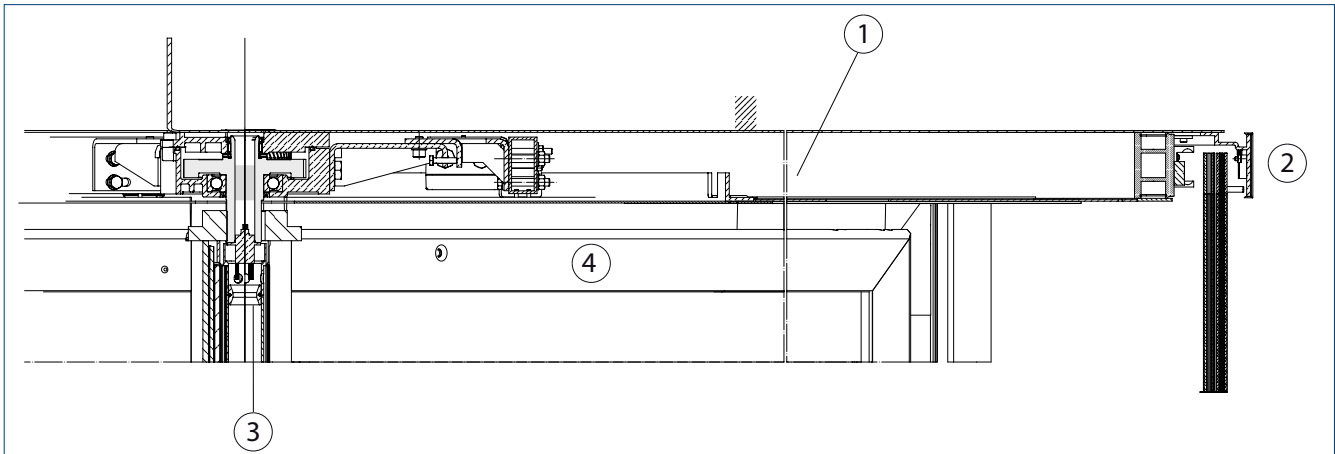

1 = Ceiling construction | 2 = Canopy profile with night-time closer on the outside | 3 = Swivelling axis | 4 = Side-hung leaf

### CEILING VARIANT WITH INSIDE-RUNNING NIGHT-TIME CLOSER (INV)

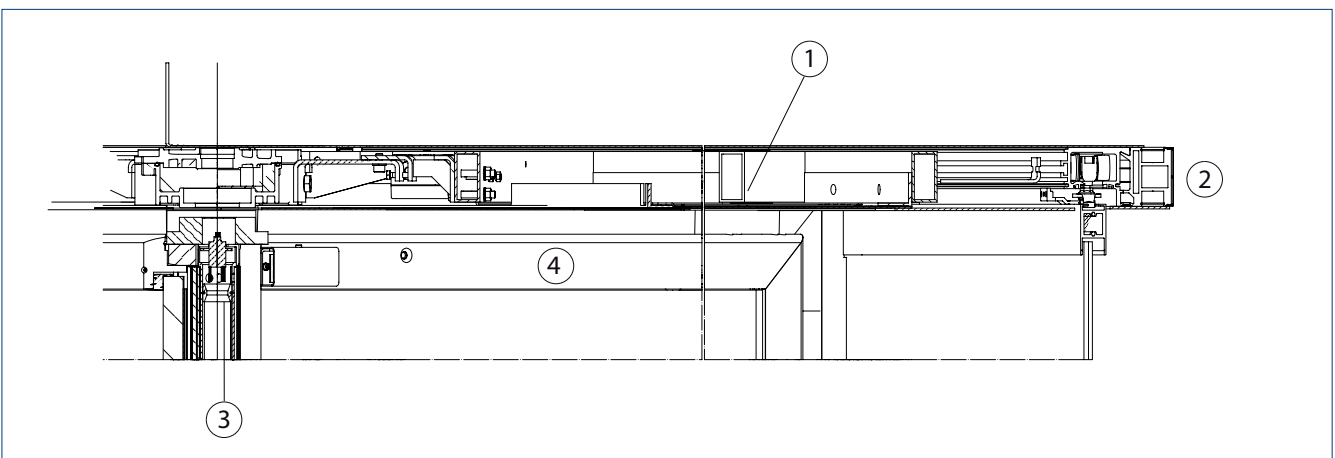

1 = Ceiling construction | 2 = Canopy profile with inside-running night-time closer | 3 = Swivelling axis | 4 = Side-hung leaf

**UNDERFLOOR DRIVE TSA 325 NT**

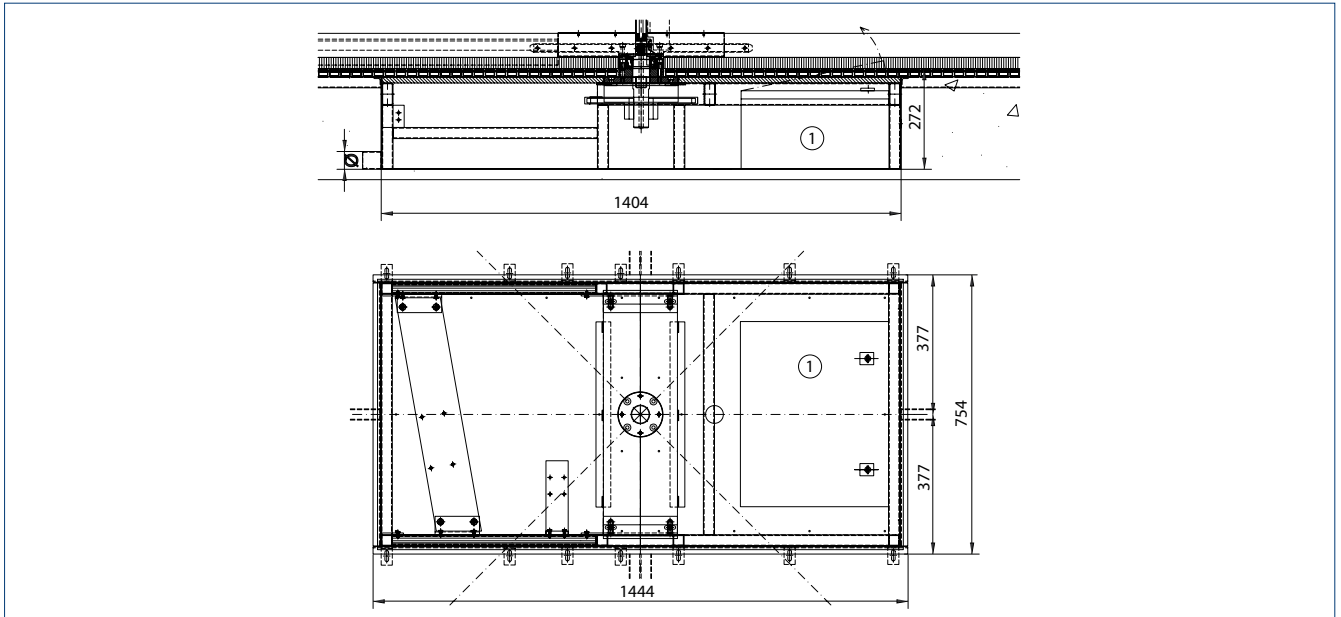

1 = Control cabinets

→ **Note:** If an external control unit is housed in a control cabinet (dimensions approx. 500 x 600 x 170 mm) at a max. distance of 20 m, a small drive box (dimensions approx. 714 x 900 x 280 mm) can be installed as well.

**AIR CURTAIN REVO.PRIME/TSA 325 NT**

**TOP OR PLAN VIEW OF AIR CURTAIN**

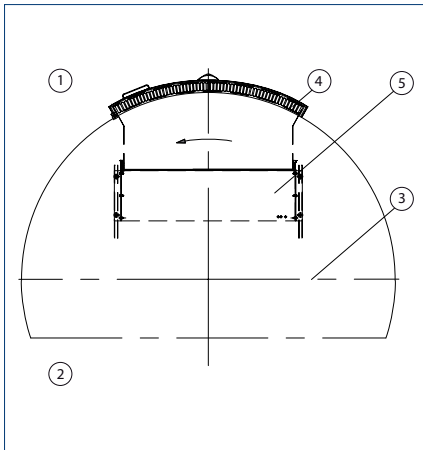

1 = Inside | 2 = Outside | 3 = Axis | 4 = Outlet duct | 5 = Air curtain

**VERTICAL SECTION OF AIR CURTAIN**

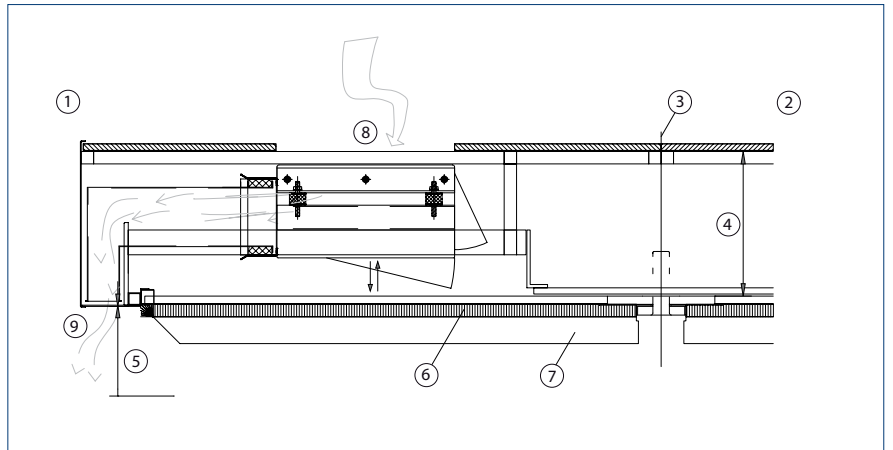

1 = Inside | 2 = Outside | 3 = Axis | 4 = Canopy height | 5 = Clear passage height | 6 = Brush | 7 = Side-hung leaf | 8 = Opening for air outlet | 9 = Extraction opening

# Cable plan TSA 325 NT– ceiling mounting

For more detailed information about connection of the activation devices and sensors see the wiring diagram 129846 (English version)

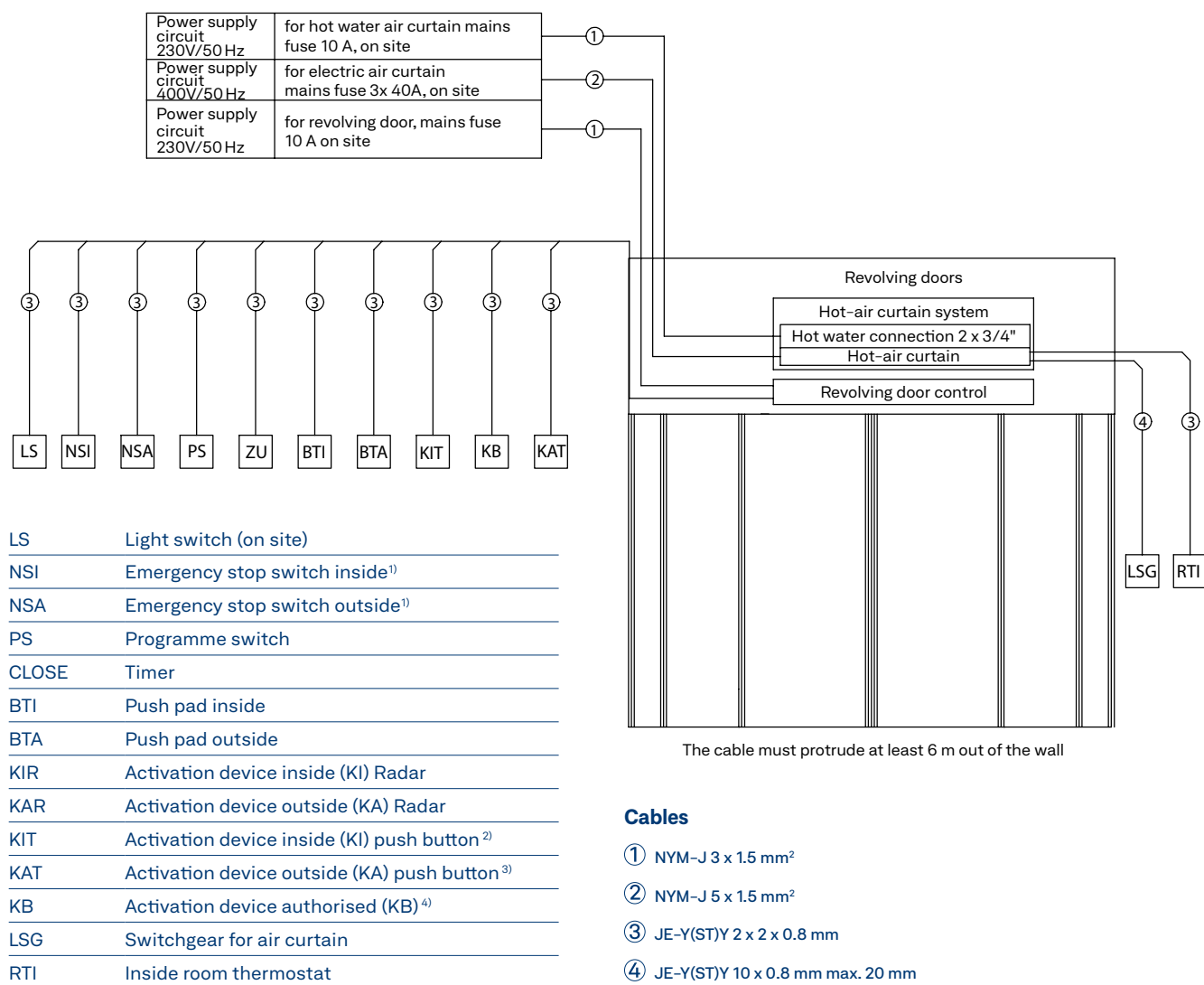

<sup>1)</sup> Install emergency stop switches at all access points

<sup>2)</sup> Several activation devices (KI) may be installed inside

<sup>3)</sup> Several activation devices (KA) may be installed outside

<sup>4)</sup> Several activation devices authorised (KB) may be installed

## Notes:

- Wiring in accordance with VDE 0100
- Wiring, connection and commissioning must only be carried out by authorised electricians.
- We will not assume any warranty or provide service if GEZE products are combined with third-party products.
- Additional activation devices for the revolving door drive are installed within the profiles located outside or within the door drum.
- The cables shown in this wiring diagram must be laid on site.
- The wiring diagram is only a schematic representation. The exact cable guide must be determined on site.
- Cable and water connections must be installed on site by a specialist company.

# Revo.PRIME cable plan

For more detailed information about connection of the activation devices and sensors see the wiring diagram 201216 (English version)

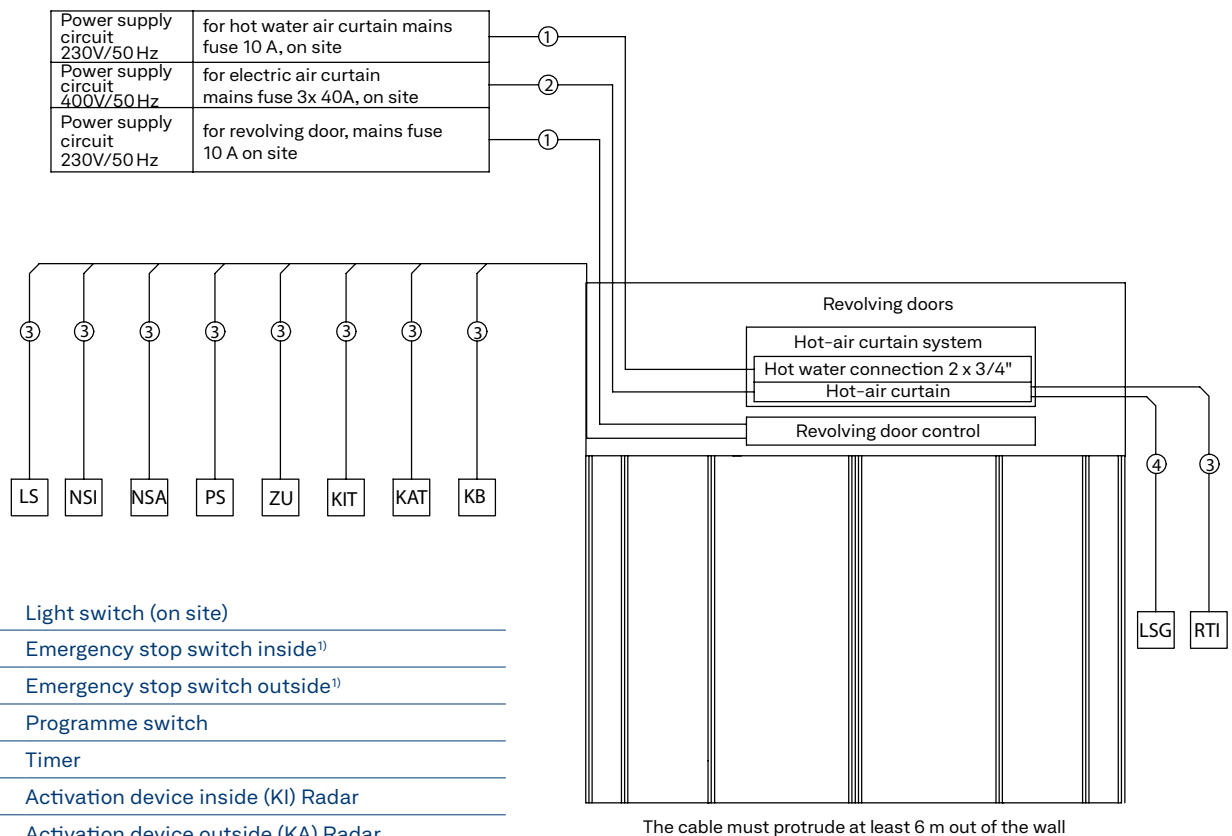

LS	Light switch (on site)
NSI	Emergency stop switch inside <sup>1)</sup>
NSA	Emergency stop switch outside <sup>1)</sup>
PS	Programme switch
ZU	Timer
KIR	Activation device inside (KI) Radar
KAR	Activation device outside (KA) Radar
KIT	Activation device inside (KI) push button <sup>2)</sup>
KAT	Activation device outside (KA) push button <sup>3)</sup>
KB	Activation device authorised (KB) <sup>4)</sup>
LSG	Switchgear for air curtain
RTI	Inside room thermostat

## Cables

- ① NYM-J 3 x 1.5 mm<sup>2</sup>
- ② NYM-J 5 x 1.5 mm<sup>2</sup>
- ③ JE-Y(ST)Y 2 x 2 x 0.8 mm
- ④ JE-Y(ST)Y 10 x 0.8 mm max. 20 mm

- <sup>1)</sup> Install emergency stop switches at all access points  
<sup>2)</sup> Several activation devices (KI) may be installed inside  
<sup>3)</sup> Several activation devices (KA) may be installed outside  
<sup>4)</sup> Several activation devices authorised (KB) may be installed

## Notes:

- Wiring in accordance with VDE 0100
- Wiring, connection and commissioning must only be carried out by authorised electricians.
- We will not assume any warranty or provide service if GEZE products are combined with third-party products.
- Additional activation devices for the revolving door drive are installed within the profiles located outside or within the door drum.
- The cables shown in this wiring diagram must be laid on site.
- The wiring diagram is only a schematic representation. The exact cable guide must be determined on site.
- Cable and water connections must be installed on site by a specialist company.

# References



Amano Hotel, Berlin, Germany (photo: Stefan Dauth / GEZE GmbH)



Akasya, Istanbul, Turkey (photo: Tarık Kaan Muşlu / GEZE GmbH)



Flight Forum, Eindhoven, Netherlands (photo: Erwin Kamphuis / GEZE GmbH)



Vector Informatik GmbH, Stuttgart-Weilimdorf, Germany (photo: Jürgen Pollak / GEZE GmbH)

# **We are GEZE.**

## **For liveable buildings**

GEZE stands for innovation, high quality and comprehensive support of building technologies. From the initial idea, planning and operational implementation with standard products to customised system solutions and individual service and maintenance plans. We offer an extensive product range of door, window and safety technology products and are a major driving force behind the digital networking of building automation.

### **GEZE GmbH**

Reinhold-Vöster-Straße 21–29  
71229 Leonberg  
Deutschland

Telefon: +49 7152 203 0

Telefax: +49 7152 203 310

E-Mail: [info.de@geze.com](mailto:info.de@geze.com)

**[www.geze.com](http://www.geze.com)**