



GEZE TSA 355/395 REVOLVING DOORS
FOCAL POINT OF THE ENTRANCE AREA



CONTENTS

| | |
|---|-----------|
| Introduction | 4 |
| GEZE TSA 355 revolving door drive | 6 |
| GEZE TSA 395 revolving door drive | 16 |
| GEZE TSA 395 Multi revolving door drive | 21 |
| Certificates | 26 |
| References | 28 |

GEZE revolving door systems

Focal point of the entrance area

The entrance area is the face of the building and thus of the enterprise. Therefore it is imperative to validate the positive visual impression through the faultless function of the door system even in the case of high access frequency. GEZE revolving doors meet these requirements and enthral planners, but also owners and users of buildings alike. The virtually unlimited design freedom and the complete selection of materials and colours meet the highest architectural requirements. Revolving doors also offer good protection against draught as they are open and closed at the same time. By eliminating draught in the entrance area, the immediate environment can be used commercially with noise, dust and dirt being kept out. The clear spatial separation between the interior and exterior as well as the energy savings offer significant cost advantages and make the use of revolving doors even more advantageous.

The scope of use of revolving doors is manifold. They are suitable for:

- Commercial buildings
- Public buildings
- Shopping centres
- Hotels and restaurants
- Administrative buildings
- Car dealerships
- Airports and railway stations

GEZE revolving doors are customised for each individual project. Various different options and versions are available. Please contact us if the variant you want differs from the dimensions and options mentioned. We offer a door for every entrance.



Tüyap Palace, Istanbul

Advantages for all target groups

Advantages for planners and builders:

- Design freedom and project specific customised planning with a range of options
- Commercial use of the entrance area for shops, offices, showrooms and a reception desk
- Harmonious visual appearance of the façade and interior
- Prestigious entrance with excellent visual effect
- Improvement of the building's energy balance
- Economical solution thanks to the high level of factory prefabrication

Advantages for users:

- Flawless and smooth operation of the door system even in the case of high access frequency.
- Easy setting of desired mode of operation
- Effective protection against noise, dust and dirt
- Protection against draught

Advantages for processors:

- Flexible modular system
- Easy installation thanks to the high level of factory prefabrication
- Predefined and programmed control technology for quick commissioning
- The door system and safety devices comply with the currently applicable standards and regulations



Latanya Otel, Ankara

GEZE TSA 355 revolving door drive

The versatile door drive

The TSA 355 model has a very wide range of applications and can be used universally. With a diameter ranging from 1800 mm to 4000 mm and a manual version or a fully automatic drive, exactly the right variant is always available. The doors can be made individually in any desired diameter and passage height. A versatile selection is also available in the surface and colour design. The door is available in 3- or 4-leaf versions and offers an additional night-time closer.

The door system has been tested and certified according to EN 16005.

Thanks to the variant with optionally available folding leaves (break-out), revolving doors are also suitable for use in escape and rescue routes, depending on building regulations and the required width of the escape route. The TSA 355 door system is the optimal solution in buildings with low as well as high public access frequency.



Hotel Hilton Garden Inn, Ankara

Technical data

| Standard features | |
|--|--|
| System | automatic |
| Emergency stop switch | one for each entrance and exit |
| Push pad | one for each entrance and exit |
| Manual operation | possible as an option |
| Radar movement detector | one for each entrance and exit |
| Front post safety sensor | one for each entrance and exit |
| Post safety | standard for each entrance |
| Curved glasses | 8 mm LSG |
| Glass for leaves | 8 mm LSG |
| Locking | manual locking/automatic locking |
| Roof | waterproof roof with waterspout |
| Brushes | 40 mm horse hair brushes |
| Ceiling | 12 segments made of 1.5 mm thick aluminium sheet |
| Glass seal | EPDM |
| Canopy | aluminium profile, canopy height 200 mm/300 mm possible (depending on diameter) |
| Colour | natural anodised or RAL colours |
| Illumination | 4 x 10 W LED downlight |
| Control panel | control panel with position switch |
| Optional features | |
| Stainless steel cladding | • |
| Gold coloured stainless steel cladding | • |
| Entrance mat | • |
| Door handle | • |
| Coloured glass | • |
| Passage height in various dimensions | • |
| Canopy height in different dimensions | • |
| Night-time closer | • |
| Break-out leaves | • |
| Manual locking + switch | • |
| Waterproof roof for the exterior, with drain channel | • |
| 2 pcs. downlights extra | • |
| 20x30x2 mm stainless steel floor ring | • |
| Hot-air curtain | • |
| Control panel with touchscreen | • |

Technical data

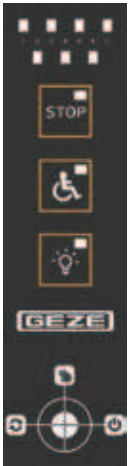

Standard

- Error detection combined with flashing LEDs
- On/off switch for lighting
- Programme switch for change between modes of operation Automatic, Manual and Night



Optional touch panel

- On/off switch for lighting
- Modes for testing and error detection
- Setting speed control and waiting periods
- Setting for limiting the torque
- Settings for stop and start periods
- All revolving door settings can be made using this touch screen



Post safety



Front post safety sensor



Access for people with disabilities and for the elderly



Light curtain



Push pad



Heel protection



Emergency stop switch

Technical data (4-leaf)

FRONTAL VIEW

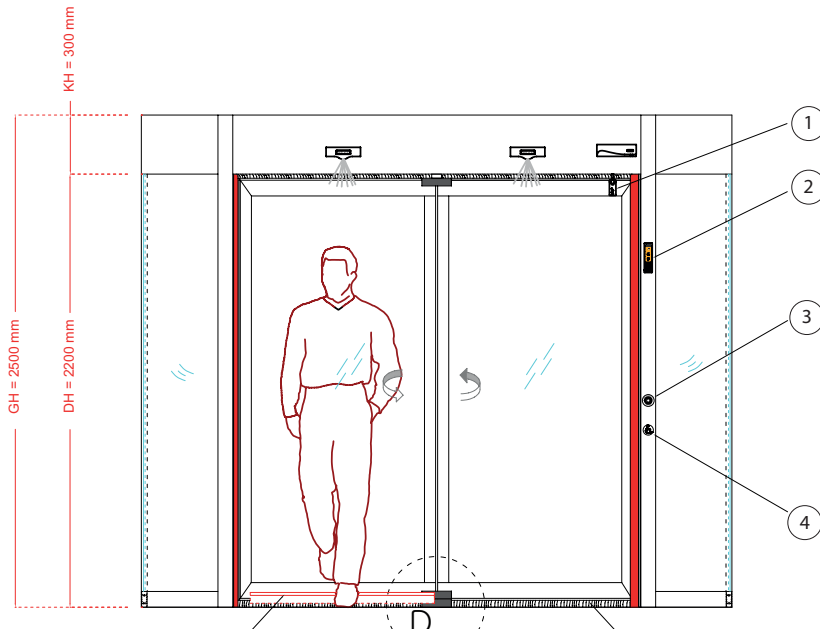

- | | |
|------------------------------------|---------------------|
| 1 = Manual locking | GH = Total height |
| 2 = Control panel/programme switch | DH = Passage height |
| 3 = Emergency stop switch | KH = Canopy height |
| 4 = Push pad | |
| 5 = Brush sealing | |
| 6 = Heel protection | |

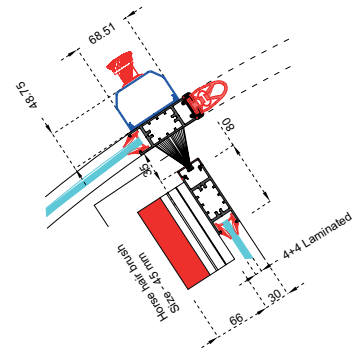

DETAIL A

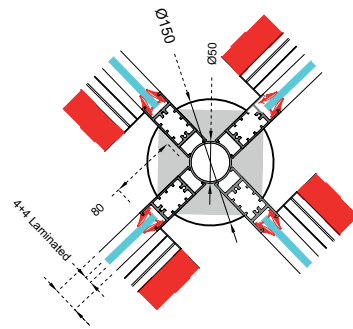

DETAIL B

PLAN VIEW

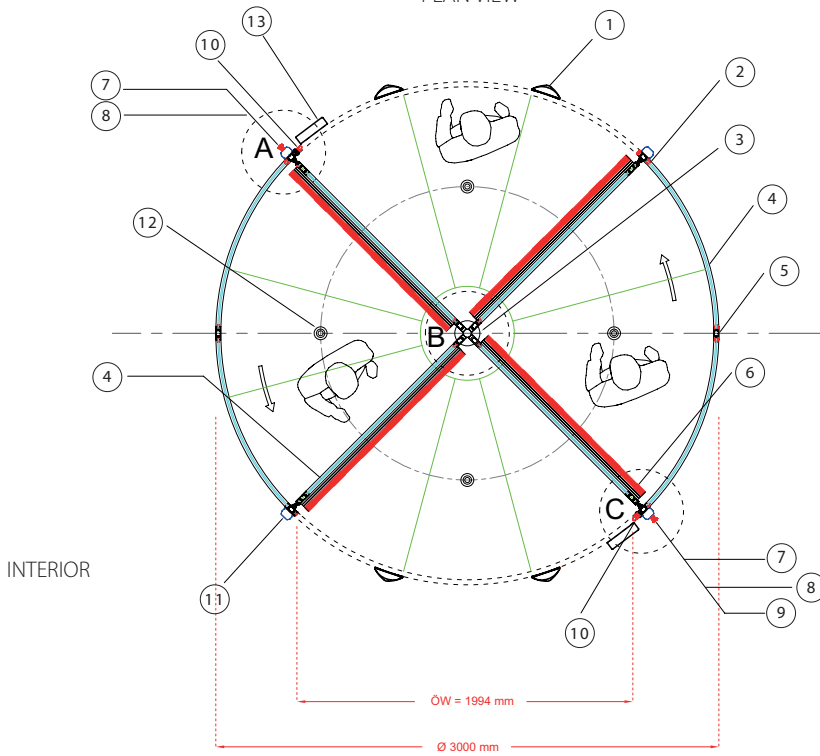

INTERIOR

- | | |
|--------------------------------|------------------------------------|
| 1 = Radar movement detector | 8 = Push pad |
| 2 = Glass sealing | 9 = Control panel/programme switch |
| 3 = Central shaft | 10 = Post safety |
| 4 = 8 mm LSG | 11 = Post attachment profile |
| 5 = 80x30 mm aluminium profile | 12 = 10 W LED |
| 6 = Heel protection | 13 = Front post safety sensor |
| 7 = Emergency stop switch | ÖW = Opening width |

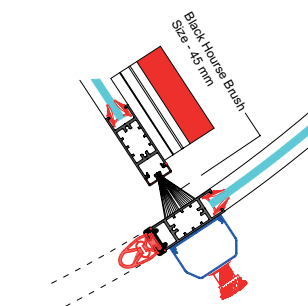

DETAIL C

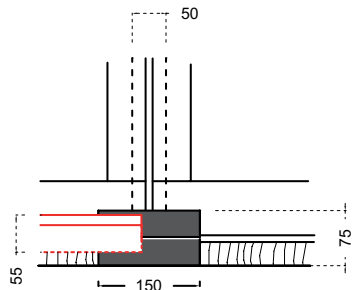

DETAIL D

Technical data (3-leaf)

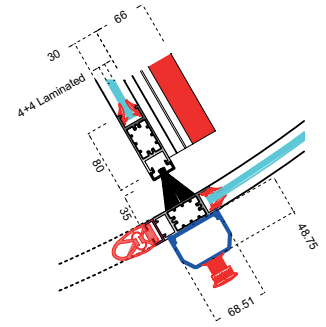
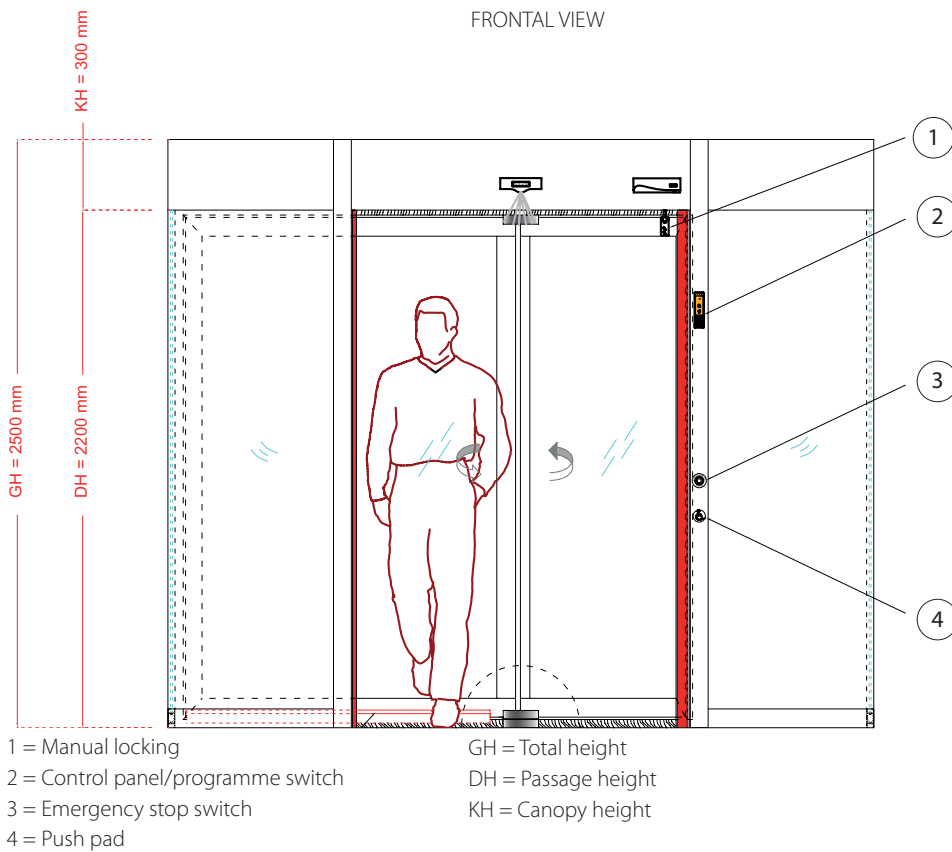

DETAIL A

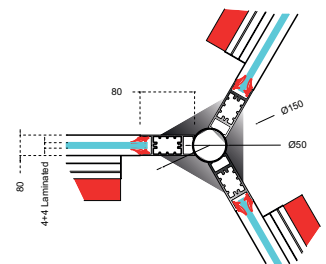

DETAIL B

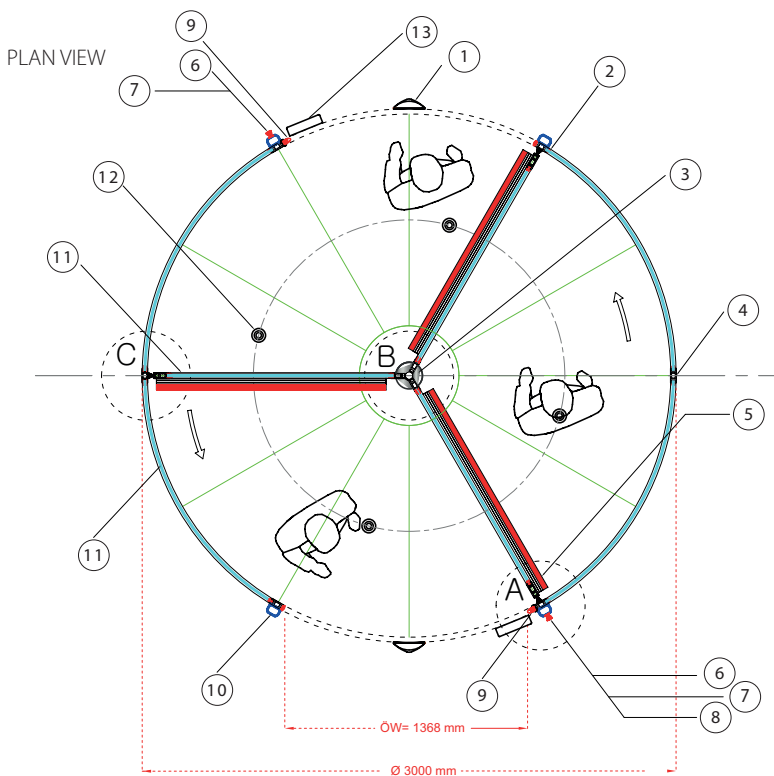

- | | |
|--------------------------------|-------------------------------|
| 1 = Radar movement detector | 8 = Control panel |
| 2 = Glass sealing | 9 = Post safety |
| 3 = Central shaft | 10 = Post attachment profile |
| 4 = 80x30 mm aluminium profile | 11 = 10 mm LSG |
| 5 = Heel protection | 12 = 10 W LED |
| 6 = Emergency stop switch | 13 = Front post safety sensor |
| 7 = Push pad | ÖW = Opening width |

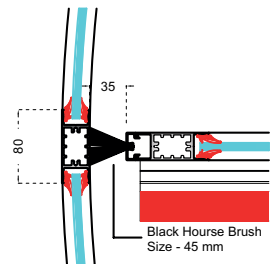

DETAIL C

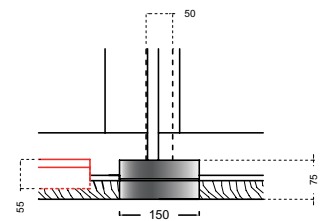

DETAIL D

Technical information automatic revolving door without central shaft

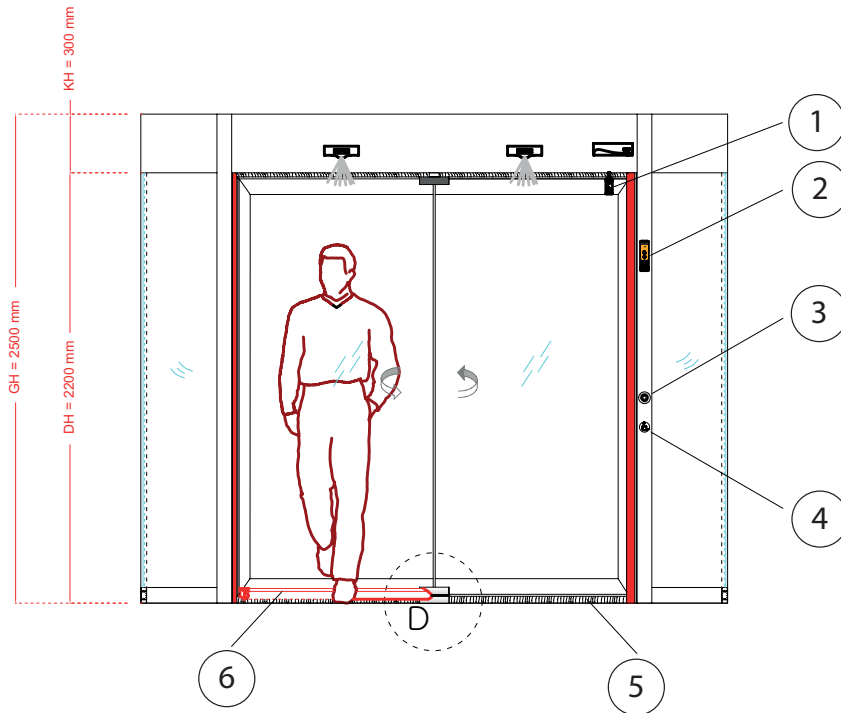

- 1 = Manual locking
- 2 = Control panel/programme switch
- 3 = Emergency stop switch
- 4 = Push pad
- 5 = Brush sealing
- 6 = Heel protection

GH = total height
 DH = Passage height
 KH = Canopy height

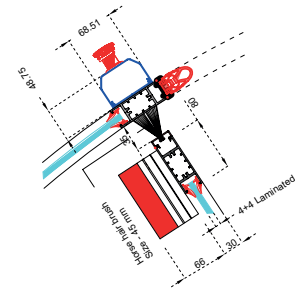

DETAIL A

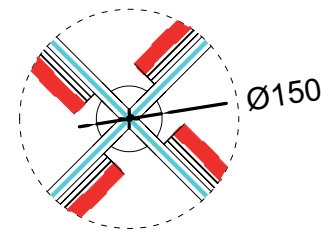

DETAIL B

PLAN VIEW

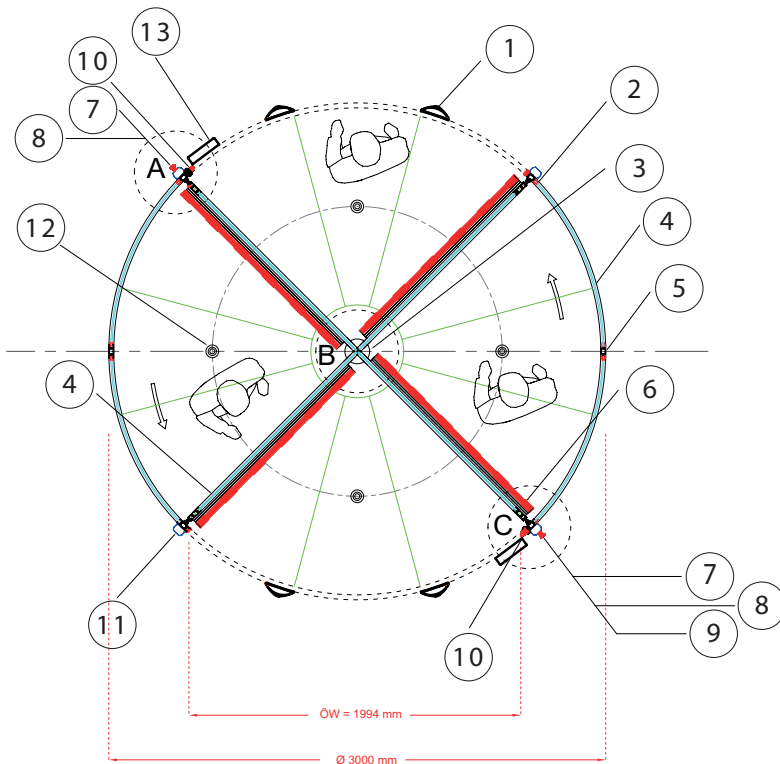

- 1 = Radar movement detector
- 2 = Glass sealing
- 3 = Central shaft
- 4 = 8 mm LSG
- 5 = 80x30 mm aluminium profile
- 6 = Heel protection
- 7 = Emergency stop switch
- 8 = Push pad
- 9 = Control panel
- 10 = Post safety
- 11 = Post attachment profile
- 12 = 10 W LED
- 13 = Front post safety sensor
- ÖW = Opening width

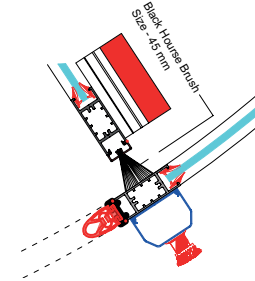

DETAIL C

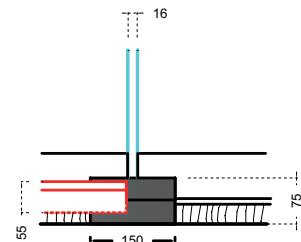

DETAIL D

GEZE TSA 355

Dimensions

| 3-leaf revolving doors | | | | | | | | | | |
|------------------------|----------------|------------|---------------|--------------------------------|----------------------------|--------------------|----------------------------|--------------------|----------------------------|--------------------|
| Outer diameter | Inner diameter | Leaf width | Passage width | Segment area in m ² | Maximum number of people * | Capacity/minute ** | Maximum number of people * | Capacity/minute ** | Maximum number of people * | Capacity/minute ** |
| 1800 | 1740 | 840 | 760 | 0.80 | 1 | 8 | 1 | 8 | 1 | 6 |
| 2000 | 1940 | 940 | 860 | 1.00 | | | | | | |
| 2200 | 2140 | 1040 | 960 | 1.25 | | | | | | |
| 2400 | 2340 | 1140 | 1060 | 1.50 | 2 | 15 | 2 | 15 | | |
| 2600 | 2540 | 1240 | 1160 | 1.75 | | | | | | |
| 2800 | 2740 | 1340 | 1260 | 2.00 | | | | | | |
| 3000 | 2940 | 1440 | 1360 | 2.35 | 4 | 30 | 3 | 23 | | |
| 3200 | 3140 | 1540 | 1460 | 2.65 | | | | | | |
| 3400 | 3340 | 1640 | 1560 | 3.00 | | | | | | |
| 3600 | 3540 | 1740 | 1660 | 3.40 | 6 | 44 | 3 | 23 | | |
| 3800 | 3740 | 1840 | 1760 | 3.75 | | | 4 | 30 | | |

All dimensions in mm

* Specifies the number of people who can be in one segment during typical use.

** Specifies the maximum number of people that can pass in one direction per minute.

| 4-leaf revolving doors | | | | | | | | | | |
|------------------------|----------------|------------|---------------|--------------------------------|----------------------------|--------------------|----------------------------|--------------------|----------------------------|--------------------|
| Outer diameter | Inner diameter | Leaf width | Passage width | Segment area in m ² | Maximum number of people * | Capacity/minute ** | Maximum number of people * | Capacity/minute ** | Maximum number of people * | Capacity/minute ** |
| 1800 | 1740 | 840 | 1140 | 0.65 | 1 | 10 | | | 1 | 10 |
| 2000 | 1940 | 940 | 1360 | 0.75 | | | | | | |
| 2200 | 2140 | 1040 | 1500 | 0.95 | | | | | | |
| 2400 | 2340 | 1140 | 1640 | 1.10 | 2 | 20 | | | | |
| 2600 | 2540 | 1240 | 1780 | 1.30 | | | | | | |
| 2800 | 2740 | 1340 | 1920 | 1.50 | 3 | 30 | 1 | 10 | | |
| 3000 | 2940 | 1440 | 2060 | 1.75 | | | | | | |
| 3200 | 3140 | 1540 | 2200 | 1.95 | | | | | | |
| 3400 | 3340 | 1640 | 2340 | 2.25 | 4 | 40 | 2 | 20 | | |
| 3600 | 3540 | 1740 | 2480 | 2.55 | | | | | | |
| 3800 | 3740 | 1840 | 2620 | 2.80 | 5 | 50 | 3 | 30 | | |

All dimensions in mm

* Specifies the number of people who can be in one segment during typical use.

** Specifies the maximum number of people that can pass in one direction per minute.

Different dimensions and equipment options available on request

Night-time closer

3-leaf

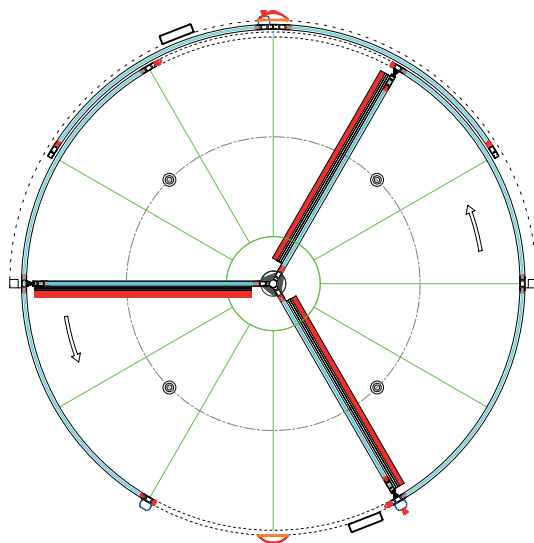
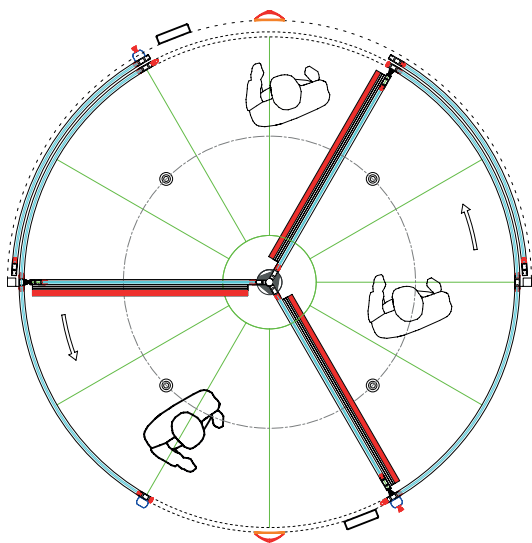

4-leaf

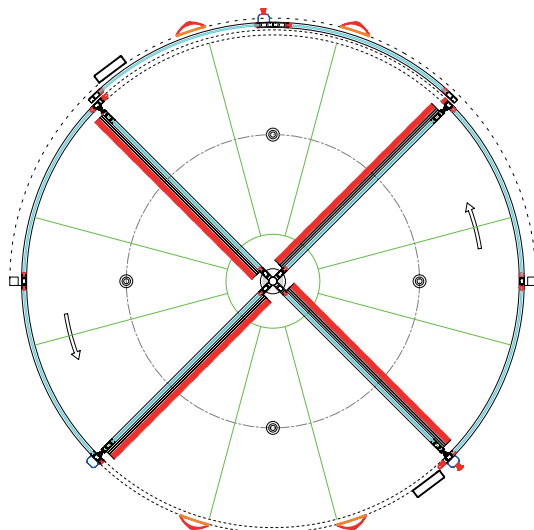
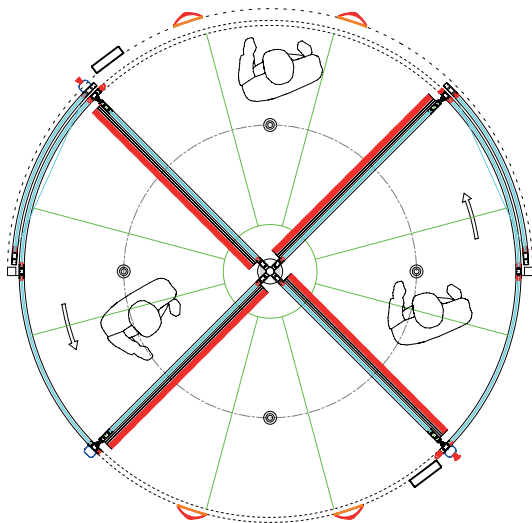

GEZE TSA 355

Variant with folding leaves (break-out)

3-leaf

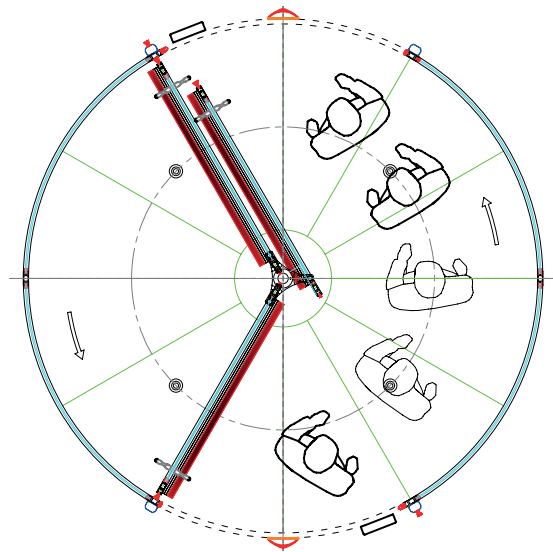
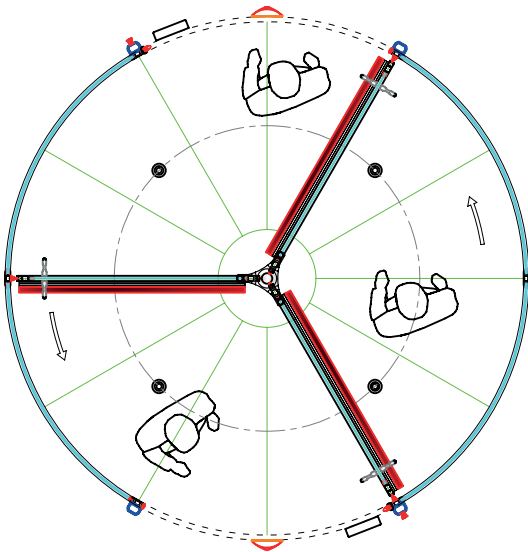

4-leaf

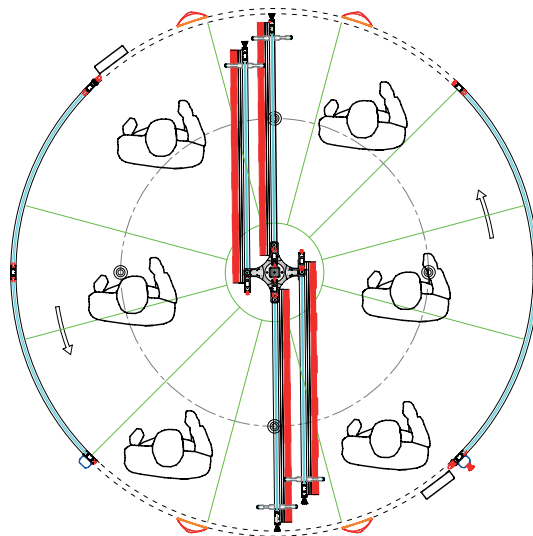
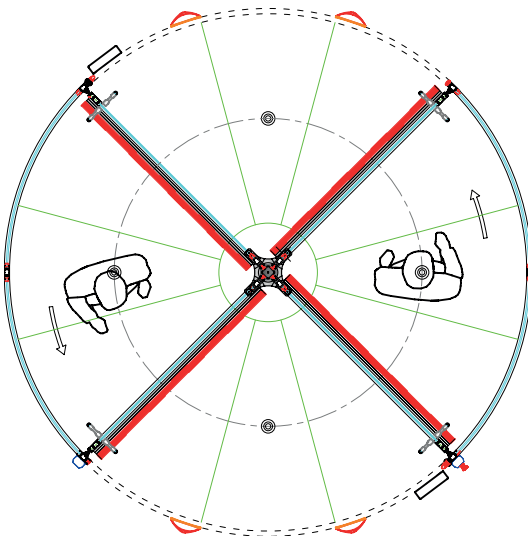

Hot-air curtains

3-leaf

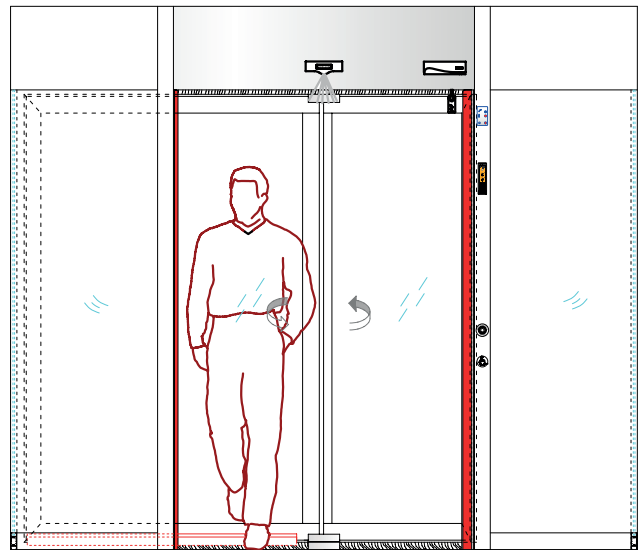
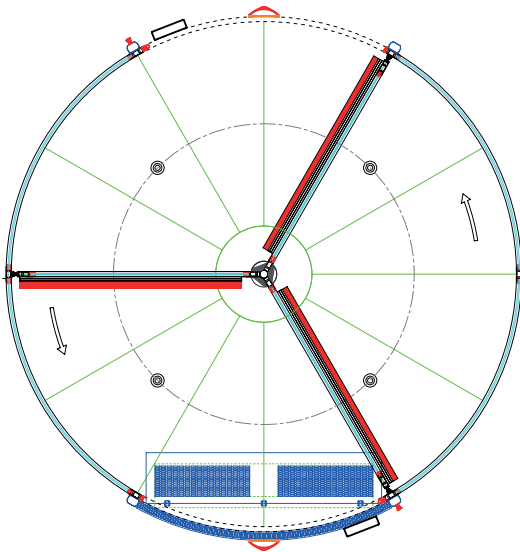

4-leaf

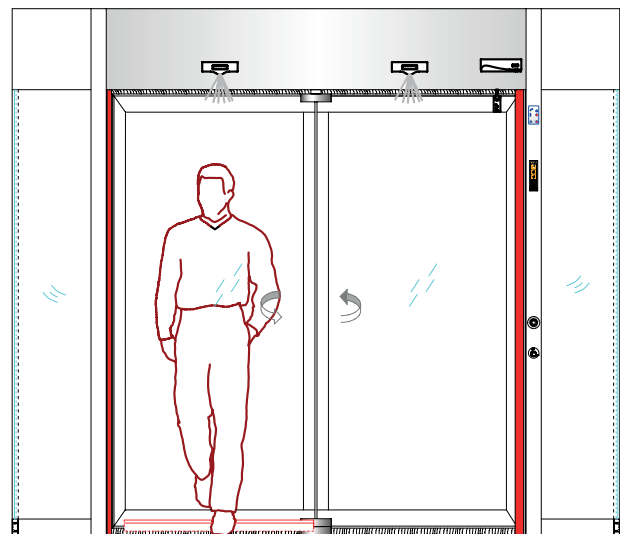
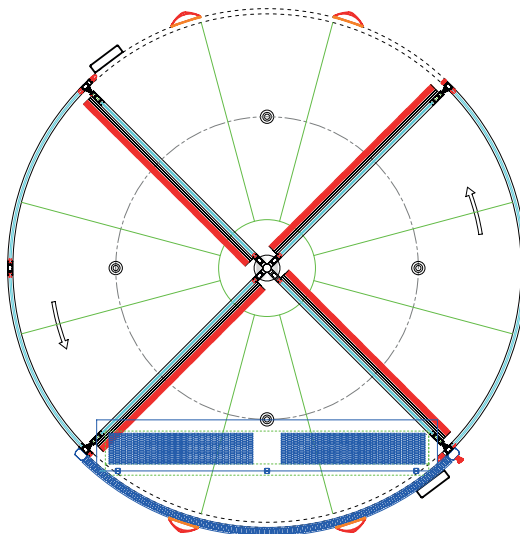

Differences between the temperature inside a building and the outside temperature cause unwanted air exchange in the door area. Air curtain systems are used to prevent this air exchange. They prevent the penetration of cold air even with revolving doors. As a result, the area directly by the door can be used economically.

GEZE TSA 395 revolving door drive

The drive for large doors

The TSA 395 model is the optimal choice for buildings with central access with high access frequency. The large door segments facilitate comfortable access to the building. This allows high visitor flows to be handled safely and representative façade entrances to be created. TSA 395 is available as a 3- or 4-leaf version up to a diameter of 6000 mm. A versatile selection is also available in the surface and colour design. A night-time closer can be selected as an additional option. Only an automatic variant is available due to the size of the door system. The central area of the door systems can optionally be equipped with a showcase for further individual design, for example for advertising purposes.

The door system has been tested and certified according to EN 16005.

Thanks to the optionally available folding leaves (break-out), revolving doors are also suitable for use in escape and rescue routes, depending on building regulations and the required width of the escape route.

This door variant is the optimal choice for projects with the following requirements:

- High person capacity
- High access convenience
- High degree of customisation in diameter, height, features and options
- Version with 3 or 4 leaves, with and without showcase

This model is particularly suitable for shopping centres, furniture stores or airports.



Galeri Resort, Antalya

Technical data

| Standard features | |
|--|---|
| System | automatic |
| Emergency stop switch | one for each entrance and exit |
| Push pad | one for each entrance and exit |
| Post safety | standard for each entrance |
| Manual stop possible | |
| Passive seal to prevent hands from becoming trapped | standard for each entrance |
| Radar movement detector | one for each entrance and exit |
| Heel protection | at the bottom of the leaves |
| Presence detector | one for each entrance and exit |
| Curved glasses | 8 mm LSG |
| Glass for leaves | 8 mm LSG |
| Locking | manual locking |
| Roof | MDF cover for the interior aluminium sheet for the exterior area |
| Brushes | 40 mm horse hair brushes |
| Ceiling | 12 segments made of 1.5 mm thick aluminium sheet |
| Glass seal | EPDM |
| Canopy | aluminium and steel profiles |
| Colour | natural anodised or RAL colours |
| Illumination | 4 x 8 W LED downlight |
| Control panel | control panel with position switch |
| Optional features | |
| Stainless steel cladding | • |
| Gold coloured stainless steel cladding | • |
| Bright stainless steel panel | • |
| Entrance mat | • |
| Door handle | • |
| Coloured glass | • |
| Heel protection for safety (below) | • |
| Passage height in various dimensions | • |
| Extra manual locking | • |
| Break-out leaves | • |
| Extra manual locking and switch | • |
| Waterproof roof for the exterior, with drain channel | • |
| 4 LED lights 10 W extra | • |
| 20x30x2 mm stainless steel floor ring | • |
| Hot-air curtain | • |

Technical data



Standard

- On/off switch for lighting
- Modes for testing and error detection
- Setting speed control and waiting periods
- Setting for limiting the torque
- Setting for start and stop periods
- All revolving door settings can be made using this touch screen

Standard



Post safety



Front post safety sensor



Access for people with disabilities and for the elderly



Mobile safeguarding device



Push pad



Heel protection



Emergency stop switch

Technical data

FRONTAL VIEW

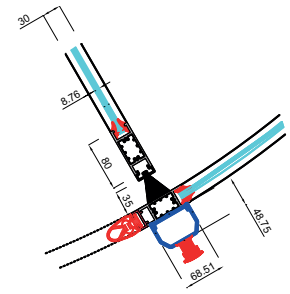
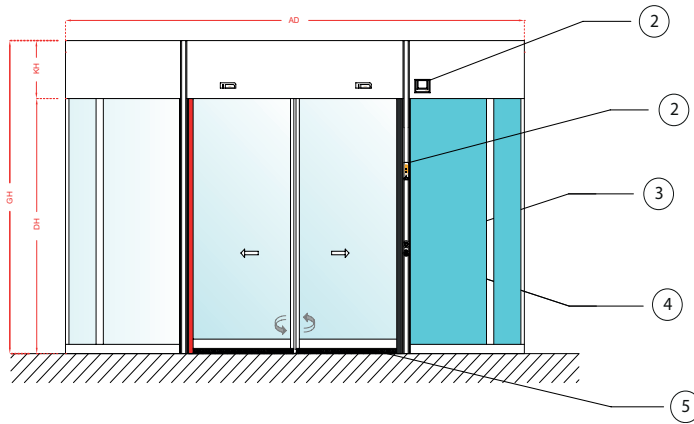

DETAIL A

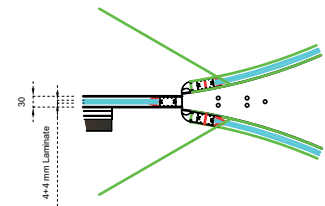

DETAIL B

- 1 = Manual locking
- 2 = Control panel/programme switch
- 3 = Emergency stop switch
- 4 = Push pad
- 5 = Brush sealing

- AD = Outer diameter
- GH = Total height
- DH = Passage height
- KH = Canopy height

PLAN VIEW

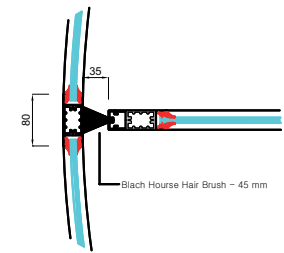
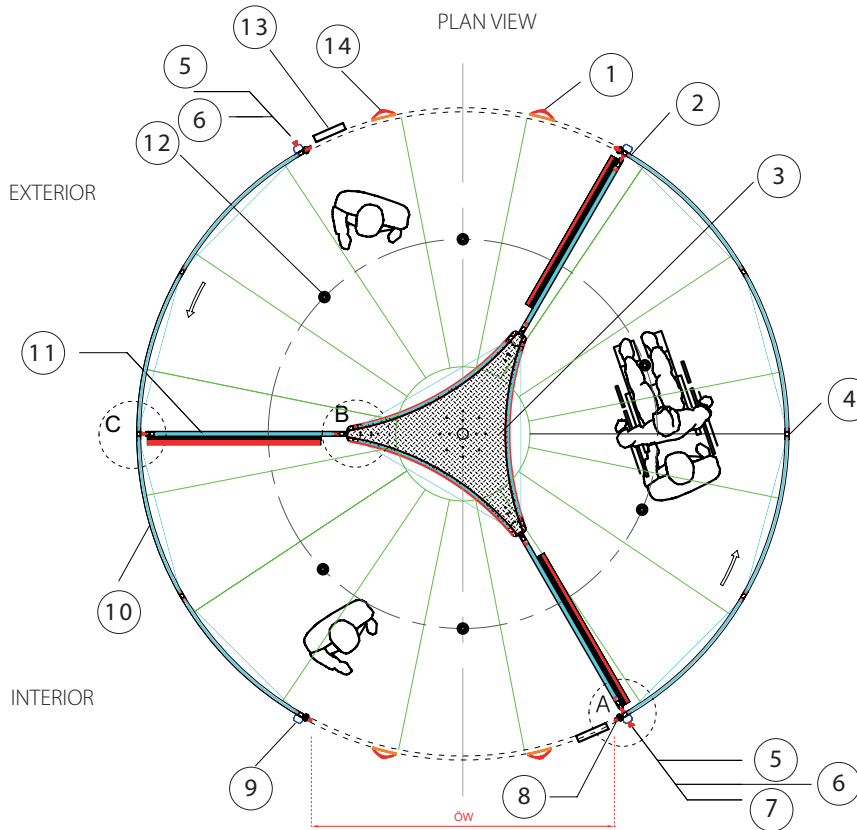

DETAIL C

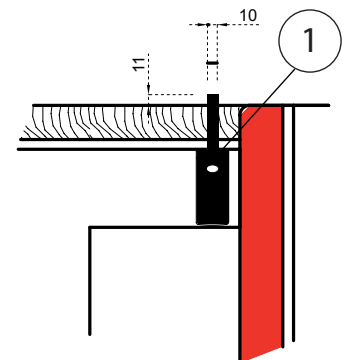

DETAIL D

- 1 = Manual locking

- 1 = Radar movement detector
- 2 = Glass sealing
- 3 = Integrated showcase
- 4 = 80x30 mm aluminium profile
- 5 = Emergency stop switch
- 6 = Push pad
- 7 = Control panel

- 8 = Post safety
- 9 = Attachment profile post
- 10 = 8 mm LSG
- 11 = 8 mm LSG
- 12 = 10 Watt LED
- 13 = Front post safety sensor
- 14 = Radar movement detector
- ÖW = Opening width

GEZE TSA 395

Dimensions

| 3-leaf revolving doors | | | | | Maximum number of people * | Capacity/minute ** | Maximum number of people * | Capacity/minute ** |
|--|----------------|------------|---------------|--------------------------------|----------------------------|--------------------|----------------------------|--------------------|
| Outer diameter | Inner diameter | Leaf width | Passage width | Segment area in m ² | | | | |
| 3-leaf with triangular showcase | | | | | | | | |
| 4000 | 3940 | 1270 | 1800 | 3.60 | 7 | 53 | 2 | 15 |
| 4500 | 4440 | 1520 | 2050 | 4.65 | 8 | 60 | 2 | 15 |
| 5000 | 4940 | 1770 | 2300 | 5.90 | 10 | 75 | 3 | 22 |
| 6000 | 5940 | 2270 | 2820 | 8.70 | 15 | 112 | 4 | 30 |
| 3-leaf without showcase | | | | | | | | |
| 4000 | 3940 | 1740 | 1800 | 4.05 | 9 | 68 | 2 | 15 |
| 4500 | 4440 | 1990 | 2050 | 5.15 | 10 | 75 | 2 | 15 |
| 5000 | 4940 | 2240 | 2300 | 6.35 | 14 | 105 | 3 | 22 |

All dimensions in mm

* Specifies the number of people who can be in one segment during typical use.

** Specifies the maximum number of people that can pass in one direction per minute.

| 4-leaf revolving doors | | | | | Maximum number of people * | Capacity/minute ** | Maximum number of people * | Capacity/minute ** |
|------------------------------------|----------------|------------|---------------|--------------------------------|----------------------------|--------------------|----------------------------|--------------------|
| Outer diameter | Inner diameter | Leaf width | Passage width | Segment area in m ² | | | | |
| 4-leaf with square showcase | | | | | | | | |
| 4000 | 3940 | 1320 | 2700 | 2.45 | 6 | 60 | 1 | 10 |
| 4500 | 4440 | 1570 | 3000 | 3.30 | 8 | 82 | 2 | 20 |
| 5000 | 4940 | 1850 | 3400 | 4.20 | 11 | 110 | 2 | 20 |
| 6000 | 5940 | 2320 | 4170 | 6.30 | 14 | 140 | 3 | 30 |
| 4-leaf without showcase | | | | | | | | |
| 4000 | 3940 | 1740 | 2700 | 3.05 | 7 | 70 | 1 | 10 |
| 4500 | 4440 | 1990 | 3000 | 3.85 | 9 | 90 | 2 | 20 |
| 5000 | 4940 | 2240 | 3400 | 4.80 | 11 | 110 | 2 | 20 |

All dimensions in mm

* Specifies the number of people who can be in one segment during typical use.

** Specifies the maximum number of people that can pass in one direction per minute.

Different dimensions and equipment options available are available on request

GEZE TSA 395 Multi revolving door drive

The universal door drive

The TSA 395 Multi model is the optimal choice for buildings with central access with high access frequency. Due to the 2-leaf design in the door area, there are particularly large segments which allow for comfortable building access. As a result, this door variant can also be used with luggage or shopping trolleys as well as by wheelchair users with an accompanying person. As a revolving door with an integrated linear sliding door, this door system is very flexible. The sliding door function also allows for the comfortable transport of longer objects or the passage of larger groups of people in the shortest time possible. The model is available up to a diameter of 5400 mm and creates representative entrances.

A versatile selection is also available in the surface and colour design. The laterally integrated showcases can optimally be used for advertising purposes. At night, the showcases are placed in front of the entrance.

This door variant is optimal in projects with the following requirements:

- High person capacity
- High access convenience
- Version with 2 door leaves and integrated sliding door

This model is therefore ideal for use in shopping centres, furniture stores and airports.



Forum Kayseri

GEZE TSA 395 MULTI

Technical data

| Standard features | |
|--|---|
| System | automatic |
| Emergency stop switch | one for each entrance and exit |
| Push pad | one for each entrance and exit |
| Post safety | standard for each entrance |
| Passive seal to prevent hands from becoming trapped | standard for each entrance |
| Radar movement detector | one for each entrance and exit |
| Heel protection | at the bottom of the leaves |
| Presence detector | one for each entrance and exit |
| Curved glasses | 8 mm LSG |
| Glass for leaves | 8 mm LSG |
| Roof | MDF cover for the interior aluminium sheet for the exterior area |
| Brushes | 70 mm horse hair brushes |
| Soffit | 12 segments made of 1.5 mm thick aluminium sheet |
| Glass seal | EPDM |
| Canopy | aluminium and steel profiles |
| Colour | natural anodised or RAL colours |
| Illumination | 8 x 10 W LED downlight |
| Control panel | control panel with position switch |
| Optional features | |
| Stainless steel cladding | • |
| Gold coloured stainless steel cladding | • |
| Bright stainless steel panel | • |
| Entrance mat | • |
| Door handle | • |
| Coloured glass | • |
| Heel protection for safety (below) | • |
| Passage height in various dimensions | • |
| Engine block heater | • |
| Waterproof roof for the exterior, with drain channel | • |
| 4 LED lights 10 W extra | • |
| 20x30x2 mm stainless steel floor ring | • |
| Hot-air curtains | • |

Technical data



Standard

- On/off switch for lighting
- Modes for testing and error detection
- Setting speed control and waiting periods
- Setting for limiting the torque
- Setting for start and stop periods
- All revolving door settings can be made using this touch screen

Standard



Post safety



Presence detector



Access for people with disabilities and for the elderly



Heel protection



Push pad



Emergency stop switch



Mobile safeguarding devices

GEZE TSA 395 MULTI

Technical data

FRONTAL VIEW

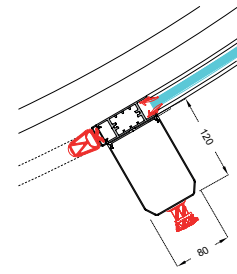
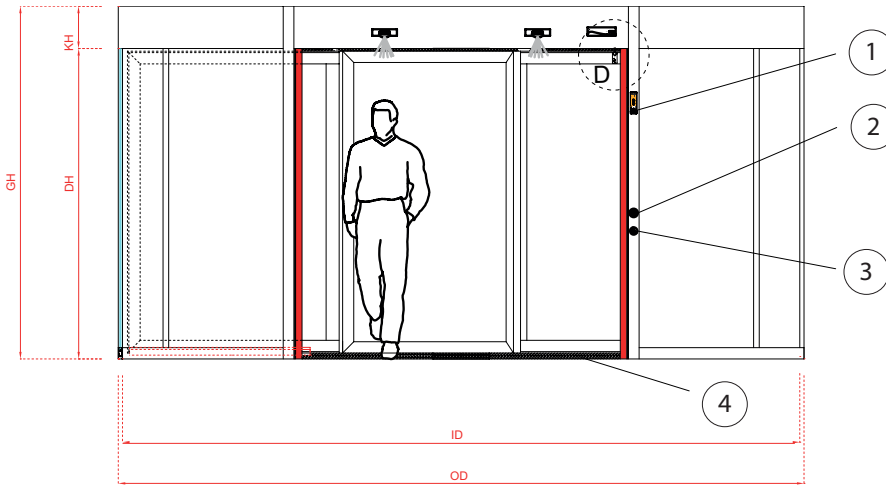

DETAIL A

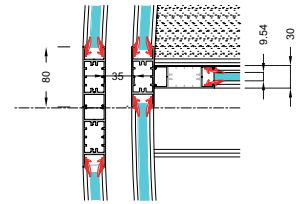

DETAIL B

- 1 = Control panel
- 2 = Emergency stop switch
- 3 = Push pad
- 4 = Brush sealing

- ID = Inner diameter
- AD = Outer diameter
- GH = Total height
- DH = Passage height
- KH = Canopy height

PLAN VIEW

EXTERIOR

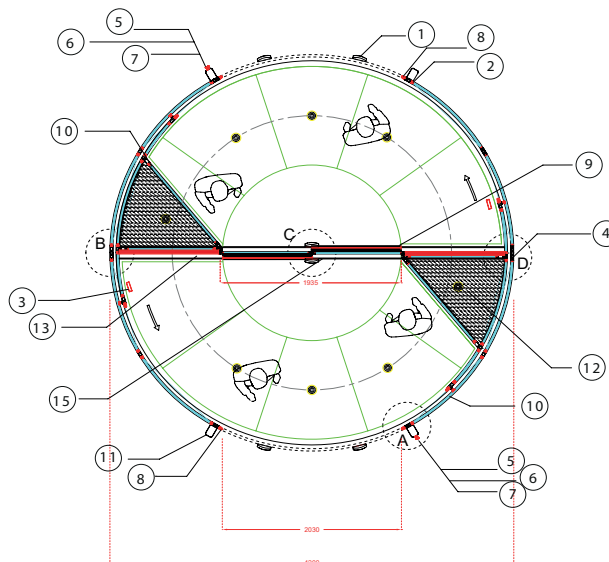

INTERIOR

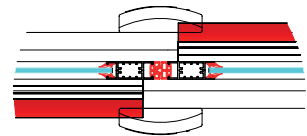

DETAIL C

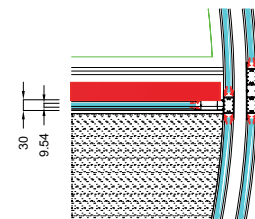

DETAIL D

- 1 = Radar movement detector
- 2 = Glass sealing
- 3 = Presence detector
- 4 = 80x30 mm aluminium profile
- 5 = Emergency stop switch
- 6 = Push pad
- 7 = Control panel
- 8 = Hand sensor
- 9 = Post safety
- 10 = 4 mm + 4 mm LSG
- 11 = Sensor cover
- 12 = 10 W LED
- 13 = Light curtain sensor
- 14 = Radar movement detector
- 15 = Sliding door
- ÖW = Opening width

Dimensions

| Outer diameter | Inner diameter | Door system installation width | Passage width revolving door | Passage width sliding door | Maximum number of persons * | Capacity/minute ** | Maximum number of persons * | Capacity/minute ** |
|----------------|----------------|--------------------------------|------------------------------|----------------------------|-----------------------------|--------------------|-----------------------------|--------------------|
| 3600 | 3540 | 3840 | 1530 | 1650 | 5 | 75 | 2 | 8 |
| 4200 | 4140 | 4440 | 1780 | 1930 | 7 | 95 | 2 | 8 |
| 4500 | 4440 | 4740 | 1980 | 2040 | 8 | 100 | 3 | 10 |
| 4800 | 4740 | 5040 | 2030 | 2200 | 9 | 105 | 3 | 12 |
| 5400 | 5340 | 5640 | 2290 | 2480 | 11 | 115 | 3 | 12 |

All dimensions in mm

* Specifies the number of people who can be in one leaf during typical use.

** Specifies the maximum number of people that can pass in one direction per minute.

Automatic operation revolving door

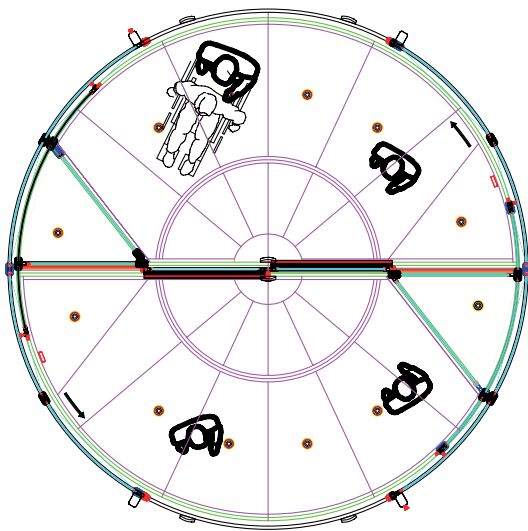

Position night/locked

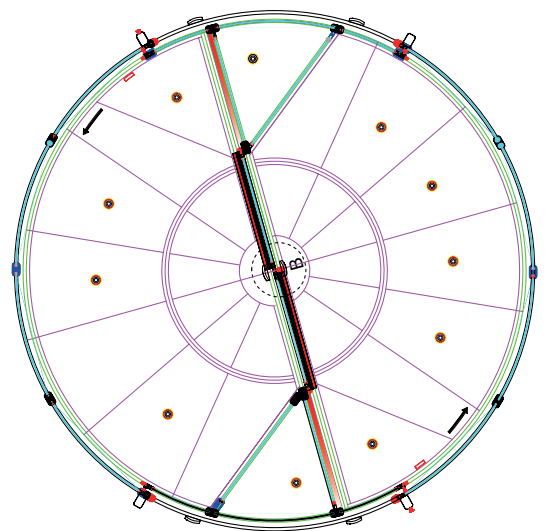

Position sliding door operation

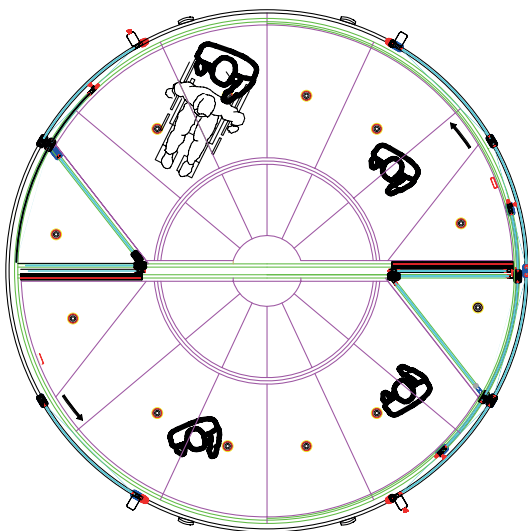

References



University of Manchester, Great Britain



Conforium Hotel, Istanbul, Turkey

GEZE AUTOMATIC REVOLVING DOOR SYSTEMS



Shopping centre, Özdemir Park, Zonguldak, Turkey



Ankara Ticaret Merkezi office building, Ankara, Turkey

POTENTIAL APPLICATIONS OF GEZE PRODUCTS

| Door technology | |
|--|---|
| 01 | Overhead door closers |
| 02 | Hold-open systems |
| 03 | Integrated door closers |
| 04 | Floor springs and all-glass fittings |
| 05 | Sliding fitting systems and linear guides |
| Automatic door systems | |
| 06 | Swing doors |
| 07 | Sliding, telescopic and folding doors |
| 08 | Curved sliding doors |
| 09 | Revolving doors |
| 10 | Activation devices and sensors |
| Smoke and heat extraction and window technology | |
| 11 | Fanlight opening systems |
| 12 | Electric opening and locking systems |
| 13 | Electrical spindle and linear drives |
| 14 | Electric chain drives |
| 15 | Smoke and heat extraction systems |
| Safety technology | |
| 16 | Emergency exit systems |
| 17 | Access control systems |
| 18 | Panic locks |
| 19 | Electric strikes |
| 20 | Building management system |
| Glass systems | |
| 21 | Manual sliding wall systems (MSW) |
| 22 | Integrated all-glass systems (IGG) |



POTENTIAL APPLICATIONS OF GEZE PRODUCTS



Door technology

The functionality, superior performance and reliability of GEZE door closers are impressive. A common design across the range, the ability to use them on all common door leaf widths and weights, and the fact that they can be individually adjusted makes their selection simple. They are continually being improved and enhanced with up-to-date features. For example, the requirements of fire protection and accessibility are fulfilled with a door closer system.

Automatic door systems

GEZE automatic door systems open up a huge variety of options in door design. The latest, innovative high-performance drive technology, safety, ease of accessibility and first class universal drive design set them apart. GEZE offers complete solutions for individual requirements.

Smoke and heat extraction and window technology

GEZE smoke and heat extraction systems and ventilation technology provide complete systems solutions combining the many requirements of different types of windows. We supply a full range from energy efficient drive systems to natural ventilation and complete solutions for supplying and extracting air, also as certified SHEVs.

Safety technology

GEZE safety technology sets the standards where preventative fire protection, access control and anti-theft security in emergency exits are concerned. For each of these objectives GEZE offers tailored solutions, which combine the individual safety requirements in one intelligent system and close doors and windows in case of danger in a coordinated manner.

Building systems

In GEZE's Building Management System GEZE door, window and safety products can be integrated in to the security and control systems of the building. A central control and visualisation system monitors various automation components in the building and offers security through many different networking capabilities.

Glass systems

GEZE glass systems stand for open and transparent interior design. They can either blend discreetly into the architecture of the building or stand out as an accentuated feature. GEZE offers a wide variety of technologies for functional, reliable and aesthetic sliding wall or sliding door systems providing security with lots of design scope.

GEZE GmbH
P.O. Box 1363
71226 Leonberg
Germany

GEZE GmbH
Reinhold-Vöster-Straße 21-29
71229 Leonberg
Germany
Tel. +49 7152 203 0
Fax +49 7152 203 310
www.geze.com

Germany
 GEZE GmbH
 Niederlassung Süd-West
 Breitwiesenstraße 8
 71229 Leonberg
 Tel. +49 7152 203 594
 Fax +49 7152 203 438
 leonberg.de@geze.com

GEZE GmbH
 Niederlassung Süd-Ost
 Parking 17
 85748 Garching bei München
 Tel. +49 7152 203 6440
 Fax +49 7152 203 77050
 muenchen.de@geze.com

GEZE GmbH
 Niederlassung Ost
 Albert-Einstein-Ring 5
 14532 Kleinmachnow bei Berlin
 Tel. +49 7152 203 6840
 Fax +49 7152 203 76849
 berlin.de@geze.com

GEZE GmbH
 Niederlassung Mitte/Luxemburg
 Siemensstraße 14
 63263 Neu-Isenburg
 Tel. +49 7152 203 6888
 Fax +49 7152 203 6891
 frankfurt.de@geze.com

GEZE GmbH
 Niederlassung West
 Heltorfer Straße 12
 40472 Düsseldorf
 Tel. +49 7152 203 6770
 Fax +49 7152 203 76770
 duesseldorf.de@geze.com

GEZE GmbH
 Niederlassung Nord
 Albert-Schweitzer-Ring 24-26 (3. OG)
 22045 Hamburg
 Tel. +49 7152 203 6600
 Fax +49 7152 203 76608
 hamburg.de@geze.com

GEZE Service GmbH
 Niederlassung Süd-West
 Reinhold-Vöster-Straße 25
 71229 Leonberg
 Tel. +49 1802 923392
 Fax +49 7152 9233 359
 service-leonberg.de@geze.com

GEZE Service GmbH
 Niederlassung Süd
 Parking 17
 85748 Garching bei München
 Tel. +49 1802 923392
 Fax +49 7152 9233 859
 service-muenchen.de@geze.com

GEZE Service GmbH
 Niederlassung Mitte/Luxemburg
 Siemensstraße 14
 63263 Neu-Isenburg
 Tel. +49 1802 923392
 Fax +49 7152 9233 659
 service-frankfurt.de@geze.com

GEZE Service GmbH
 Niederlassung West
 Heltorfer Straße 12
 40472 Düsseldorf
 Tel. +49 1802 923392
 Fax +49 7152 9233 559
 service-duesseldorf.de@geze.com

GEZE Service GmbH
 Niederlassung Ost
 Albert-Einstein-Ring 5
 14532 Kleinmachnow bei Berlin
 Tel. +49 1802 923392
 Fax +49 7152 9233 759
 service-berlin.de@geze.com

GEZE Service GmbH
 Niederlassung Nord
 Albert-Schweitzer-Ring 24-26 (3. OG)
 22045 Hamburg
 Tel. +49 1802 923392
 Fax +49 7152 9233 459
 service-hamburg.de@geze.com

Austria
 GEZE Austria
 Wiener Bundesstrasse 85
 A-5300 Hallwang
 Tel: +43 6225 87180
 Fax +43 6225 87180 299
 austria.at@geze.com

Baltic States –
Lithuania / Latvia / Estonia
 Tel. +371 678960 35
 baltic-states@geze.com

Benelux
 GEZE Benelux B.V.
 Industrieterrein Kapelbeemd
 Steenoven 36
 5626 DK Eindhoven
 Tel. +31 4026290 80
 Fax +31 4026290 85
 benelux.nl@geze.com

Bulgaria
 GEZE Bulgaria - Trade
 Representative Office
 Nickolay Haitov 34 str., fl. 1
 1172 Sofia
 Tel. +359 247043 73
 Fax +359 247062 62
 office-bulgaria@geze.com

China
 GEZE Industries (Tianjin) Co., Ltd.
 Shuangchenzhong Road
 Beichen Economic Development
 Area (BEDA)
 Tianjin 300400, P.R. China
 Tel. +86 22 26973995
 Fax +86 22 26972702
 chinasales@geze.com.cn

GEZE Industries (Tianjin) Co., Ltd.
 Branch Office Shanghai
 Jia Little Exhibition Center
 Room C 2-102
 Shenzhuan Rd. 6000
 201619 Shanghai, P.R. China
 Tel. +86 21 52340960
 Fax +86 21 64472007
 chinasales@geze.com.cn

GEZE Industries (Tianjin) Co., Ltd.
 Branch Office Guangzhou
 Room 17 C 3
 Everbright Bank Building, No.689
 Tian He Bei Road
 510630 Guangzhou, P.R. China
 Tel. +86 20 38731842
 Fax +86 20 38731834
 chinasales@geze.com.cn

GEZE Industries (Tianjin) Co., Ltd
 Branch Office Beijing
 Room 04-05, 7th Floor
 Red Sandalwood Plaza
 No. 27 Jianguo Road
 Chaoyang District
 100024 Beijing, P.R.China
 Tel. +86 10 85756009
 Fax +86 10 85758079
 chinasales@geze.com.cn

France
 GEZE France S.A.R.L.
 ZAC de l'Orme Rond
 RN 19
 77170 Servon
 Tel. +33 1 606260 70
 Fax +33 1 606260 71
 france.fr@geze.com

Hungary
 GEZE Hungary Kft.
 Hungary-2051 Biatorbágy
 Vendel Park
 Huber u. 1.
 Tel. +36 23532 735
 Fax +36 23532 738
 office-hungary@geze.com

Iberia
 GEZE Iberia S.R.L.
 C/ Andorra 24
 08830 Sant Boi de Llobregat
 (Barcelona)
 Tel. +34 902194 036
 Fax +34 902194 035
 info.es@geze.com

India
 GEZE India Private Ltd.
 MF 2 & 3, Guindy Industrial Estate
 Ekkattuthangal
 Chennai 600 097
 Tamilnadu
 Tel. +91 44 406169 00
 Fax +91 44 406169 01
 office-india@geze.com

Italy
 GEZE Italia S.r.l
 Sede di Vimercate
 Via Fiorbellina 20
 20871 Vimercate (MB)
 Tel. +39 0399530401
 Fax +39 039 9530459/419
 italia.it@geze.com

Sede di Roma
 Via Lucrezia Romana, 91
 00178 Roma
 Tel. +39 039 9530401
 Fax +39 039 9530449
 italia.it@geze.com

Korea
 GEZE Korea Ltd.
 T4-716 Western Tower, 24 Jeong-
 balsanro, Ilsangu Goyangsi,
 Gyeonggido, 10403, South Korea
 Tel. +82 31 814 6410
 Fax +82 31 814 6410
 info.kr@geze.com

Poland
 GEZE Polska Sp. z o.o.
 ul. Marywilska 24
 03-228 Warszawa
 Tel. +48 224 404 440
 Fax +48 224 404 400
 geze.pl@geze.com

Romania
 GEZE Romania S.R.L.
 IRIDE Business Park,
 Str. Dimitrie Pompeiu nr. 9-9a,
 Building 10, Level 2, Sector 2,
 020335 Bucharest
 Tel. +40 212507 750
 Fax +40 316201 258
 office-romania@geze.com

Russia
 OOO GEZE RUS
 Letnikovskaya str. 10/2
 Floor 6, room VII
 115114 Moscow
 Tel. +7 495 741 40 61
 office-russia@geze.com

Scandinavia – Sweden
 GEZE Scandinavia AB
 Mallslingan 10
 Box 7060
 18711 Täby, Sweden
 Tel. +46 87323 400
 Fax +46 87323 499
 sverige.se@geze.com

Scandinavia – Norway
 GEZE Scandinavia AB avd. Norge
 Industriveien 34 B
 2073 Dal
 Tel. +47 63957 200
 Fax +47 63957 173
 norge.se@geze.com

Scandinavia – Denmark
 GEZE Danmark
 Branch office of GEZE Scandinavia AB
 Märkærvej 13 L
 2630 Taastrup
 Tel. +45 463233 24
 danmark.se@geze.com

Singapore
 GEZE (Asia Pacific) Pte. Ltd.
 21 Bukit Batok Crescent
 #23-75 Wcega Tower
 Singapore 658065
 Tel. +65 6846 1338
 Fax +65 6846 9353
 gezessea@geze.com.sg

South Africa
 Geze South Africa (Pty) Ltd.
 GEZE, Building 3, 1019 Morkels Close
 Midrand 1685
 Tel. + 87 94337 88
 Fax + 86 66137 52
 info@gezesa.co.za

Switzerland
 GEZE Schweiz AG
 Zelglimatte 1A
 6260 Reiden
 Tel. +41 62 28554 00
 Fax +41 62 28554 01
 schweiz.ch@geze.com

Turkey
 GEZE Kapı ve Pencere Sistemleri
 San. ve Tic. Ltd. Sti.
 İstanbul Anadolu Yakası Organize
 Sanayi Bölgesi
 Gazi Bulvarı Caddesi 8.Sokak No:8
 Tuzla-İstanbul
 Tel. + 90 216 45543 15
 Fax + 90 216 45582 15
 office-turkey@geze.com

Ukraine
 GEZE Ukraine LLC
 45, Elektrotekhnicheskaya str.,
 Kiev, 02222
 Tel./Fax +38 445012225
 office-ukraine@geze.com

United Arab Emirates/GCC
 GEZE Middle East
 P.O. Box 17903
 Jebel Ali Free Zone
 Dubai
 Tel. +971 48833 112
 Fax +971 48833 240
 gezeme@geze.com

United Kingdom
 GEZE UK Ltd.
 Blenheim Way
 Fradley Park
 Lichfield
 Staffordshire WS13 8SY
 Tel. +44 15434430 00
 Fax +44 15434430 01
 info.uk@geze.com

GEZE REPRESENTATIVE